

Vibrating level switch

Compact version

Models TLS-CC, TLS-CM

WIKA data sheet LM 30.12



For further approvals,
see page 6

Applications

- General purpose vibrating level switch designed to suit all liquids
- Particularly suitable as overflow and dry run protection of pumps, vessels and pipelines
- Suitable for industrial applications

Special features

- Compact design
- Low maintenance costs
- Stable and reliable level detection, unaffected by flow, bubble formation, vibrations, build-up or solids in the medium



Vibrating level switch, model TLS

Description

The core element of the vibrating level switch is the vibrating fork with integrated vibration drive. When the vibrating tuning fork is immersed in the medium, the resonance frequency of the tuning fork decreases. The frequency change is detected by the electronic circuit and is converted to a switching signal. Irrespective of the mounting position, level changes can be detected very accurately.

The respective switch point can be changed via a pipe extension. The TLS-C vibrating level switch is specially designed for industrial applications and offers reliable point level detection. It is ideal for monitoring bilges and leaks as well as for point level detection in oil tanks of rotor gearboxes.

The vibrating level switches are, depending on the version, suitable for an operating temperature of $-40 \dots +150 \text{ }^{\circ}\text{C}$ [$-40 \dots +302 \text{ }^{\circ}\text{F}$] and an operating pressure of $-1 \dots +64 \text{ bar}$ [$-14 \dots +928 \text{ psi}$]. The vibrating level switch is suitable for media with a density of $500 \dots 2,500 \text{ g/cm}^3$ [$289 \dots 1,445 \text{ oz/in}^3$]. The viscosity of the media should be between 0.1 and $10,000 \text{ cP}$ [0.24 and $21,190 \text{ lb/ft-h}$].

Application example

In practice, the vibrating level switches are mainly used in two areas: Firstly, the level switches are used to detect and control high and low levels in liquid vessels. Secondly, the vibrating level switches are used to detect liquids in pipelines to prevent the pump from running dry.

Level detection for vessels

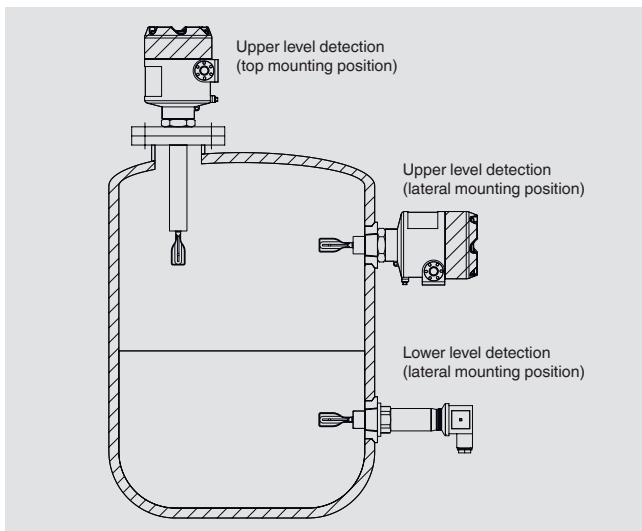

The vibrating level switch is usually installed on the side of the tank to detect the upper and lower liquid levels. If the vessel has no side openings, the limit level switch can also be mounted on the tank from above. A pipe extension is then often used to achieve the desired switch point. Installation on the underside of the tank is also possible.

Pipeline monitoring

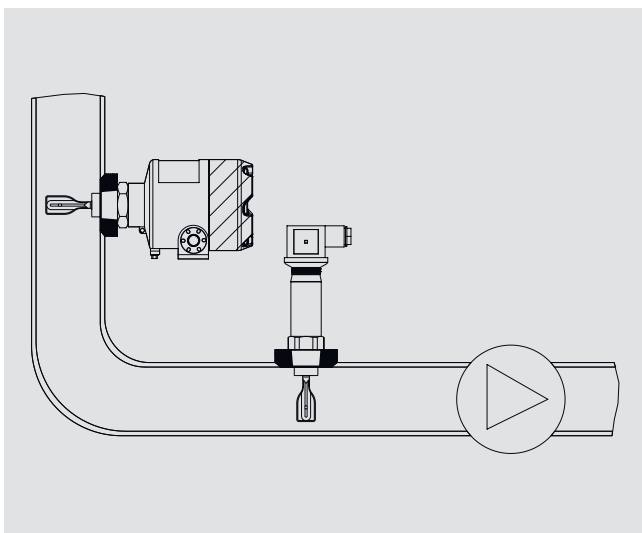

To ensure that a pump does not run dry, there must be sufficient liquid in the intake pipe. The vibrating level switch can detect this and thereby prevent damage to the pump. Since the tuning fork only protrudes 38 mm [1.5 in] into the pipeline, it can be used to measure in small diameter pipelines.

Overview of versions

Model	Description
TLS-CC	Vibrating level switch, compact version with angular connector DIN 175301
TLS-CM	Vibrating level switch, compact version with circular connector M12 x 1

Vibrating level switch TLS-CC

Compact version with angular connector DIN 175301

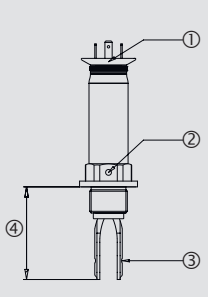
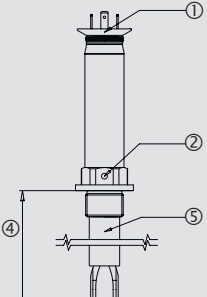
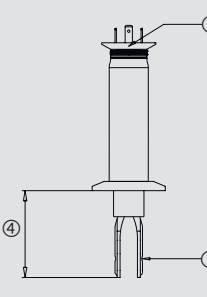
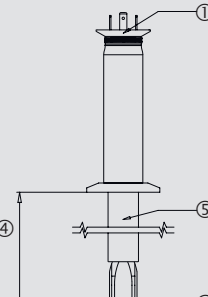
	Mounting thread	Mounting thread with extension	Clamp connection	Clamp connection with extension
① Connector ② Direction mark ③ Switch point ④ Insertion length ⑤ Extension				
Electrical connection	<ul style="list-style-type: none"> ■ 4-pin per DIN EN 175301-803 ■ M16 x 1.5 			
Process connection	<ul style="list-style-type: none"> ■ G 3/4" ... 2" ■ 3/4" ... 2" NPT 		1" ... 4" per ASME BPE	
Material				
Connection housing	Stainless steel 316L			
Wetted parts	<ul style="list-style-type: none"> ■ Stainless steel 1.4404 (316L) ■ Stainless steel 1.4404, 14435 (316L), electropolished ■ Hastelloy C-276 ■ Hastelloy C-276, electropolished 			
Ambient temperature	-40 ... +60 °C [-40 ... +140 °F]			
Supply voltage	DC 24 V			
Process temperature	-40 ... +100 °C [-40 ... +212 °F]	-40 ... +150 °C [-40 ... +302 °F]	-40 ... +100 °C [-40 ... +212 °F]	-40 ... +150 °C [-40 ... +302 °F]
Density of the medium	≥ 500 ... 2,500 kg/m ³			
Operating pressure	-1 ... +64 bar [-14.5 ... +928.3 psi]			
Switching output	<ul style="list-style-type: none"> ■ SPST relay output ■ PNP transistor output 			
Power consumption	< 1 W			
Max. switching power (relay output)	DC 30 V / 3 A			
IP ingress protection	IP65			
Insertion length	64 mm [2.52 in]	64 ... 3,000 mm [2.52 ... 118.11 in]	<ul style="list-style-type: none"> ■ 60 mm [2.36 in] ■ 43 mm [1.69 in] ■ 47 mm [1.85 in] 	60 ... 3,000 mm [2.36 ... 118.11 in]
Switch point	Switch point = insertion length - 13 mm [0.51 in]			
Tuning fork length	<ul style="list-style-type: none"> ■ 42 mm [1.65 in] ■ 38 mm [1.50 in] 			

Vibrating level switch TLS-CM

Compact version with circular connector M12 x 1

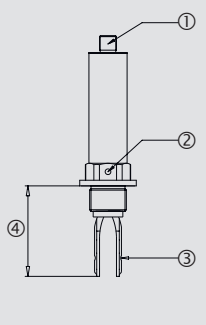
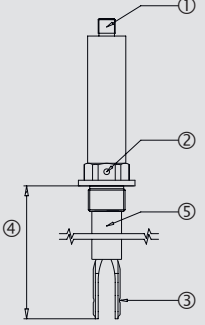
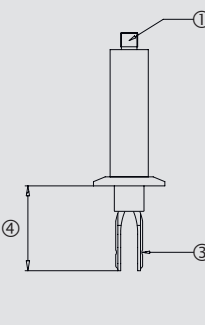
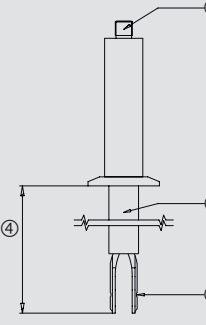
	Mounting thread	Mounting thread with extension	Clamp connection	Clamp connection with extension
① Connector ② Direction mark ③ Switch point ④ Insertion length ⑤ Extension				
Electrical connection	M12 circular connector, 4-pin			
Process connection	<ul style="list-style-type: none"> ■ G 3/4" ... 2" ■ 3/4" ... 2" NPT 		1" ... 4" per ASME BPE	
Material				
Connection housing	Stainless steel 1.4404 (316L)			
Process connection	Stainless steel 316L			
Tuning fork (wetted)	<ul style="list-style-type: none"> ■ Stainless steel 1.4404 (316L) ■ Stainless steel 1.4404, 1.4435 (316L), electropolished ■ Hastelloy C-276 ■ Hastelloy C-276, electropolished 			
Ambient temperature	-40 ... +60 °C [-40 ... +140 °F]			
Supply voltage	DC 24 V			
Process temperature	-40 ... +100 °C [-40 ... +212 °F]	-40 ... +150 °C [-40 ... +302 °F]	-40 ... +100 °C [-40 ... +212 °F]	-40 ... +150 °C [-40 ... +302 °F]
Density of the medium	≥ 500 ... 2,500 kg/m ³			
Operating pressure	-1 ... +64 bar [-14.5 ... +928.3 psi]			
Switching output	<ul style="list-style-type: none"> ■ SPST relay output ■ PNP transistor output 			
Power consumption	< 1 W			
Max. switching power (relay output)	DC 30 V / 3 A			
IP ingress protection	IP66/68			
Insertion length	64 mm [2.52 in]	64 ... 3,000 mm [2.52 ... 118.11 in]	<ul style="list-style-type: none"> ■ 60 mm [2.36 in] ■ 43 mm [1.69 in] ■ 47 mm [1.85 in] 	60 ... 3,000 mm [2.36 ... 118.11 in]
Switch point	Switch point = insertion length - 13 mm [0.51 in]			
Tuning fork length	<ul style="list-style-type: none"> ■ 42 mm [1.65 in] ■ 38 mm [1.50 in] 			

Wiring scheme

→ For details on the wiring scheme, see the model TLS installation and operating instructions, article number 14639448

TLS-CC

4-pin coupler connector per DIN EN 175301-803, with electrical connection M16 x 1.5

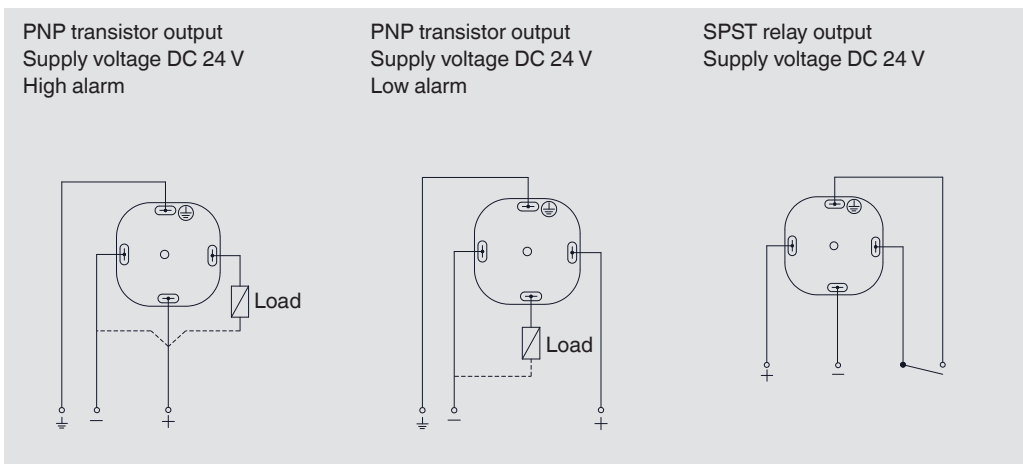

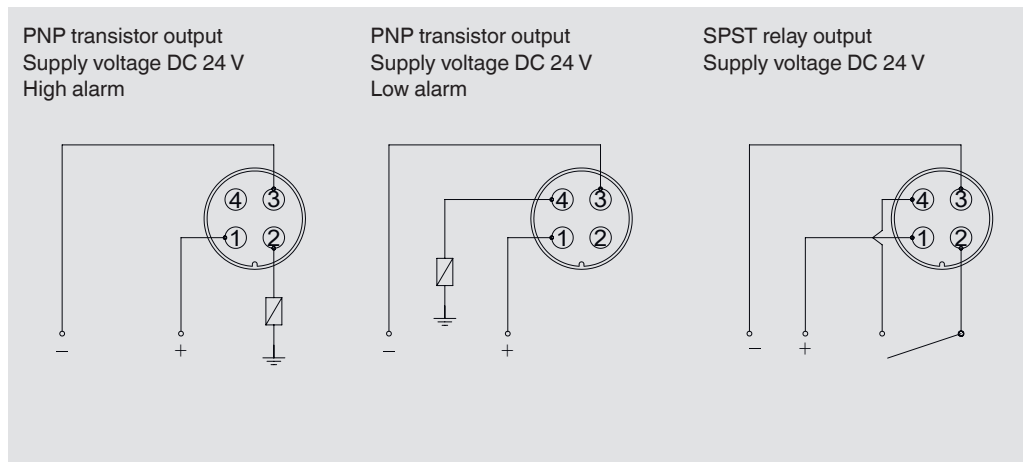

TLS-CM

Circular connector M12 x 1, 4-pin



Approvals

Logo	Description	Region
	EU declaration of conformity	European Union
	EMC directive EN 61326 emission (group 1, class B) and immunity (industrial environments)	
	RoHS directive	
	UKCA	United Kingdom
	Electromagnetic compatibility regulations	
	Restriction of hazardous substances (RoHS) regulations	

Certificates (option)

Certificates	
Certificates	<ul style="list-style-type: none"> ■ 2.2 test report per EN 10204 (e.g. state-of-the-art manufacturing, material proof) ■ 3.1 inspection certificate per EN 10204 (e.g. material proof for wetted metal parts)

Ordering information

Model / Operating pressure / Operating temperature / Material / Electrical connection / Process connection / Switching output / Insertion length

© 06/2024 WIKA Alexander Wiegand SE & Co. KG, all rights reserved.
 The specifications given in this document represent the state of engineering at the time of publishing.
 We reserve the right to make modifications to the specifications and materials.
 In case of a different interpretation of the translated and the English data sheet, the English wording shall prevail.



D-Ex Instruments, s.r.o.
 Optátova 708/37
 637 00 Brno/Czech Republic
 Mob. +420 775 757 225
 Tel. +420 541 423 225
 ksr@dex.cz
 www.dex.cz/ksr



D-Ex Instruments, s.r.o.
 Pražská 3222/1
 811 04 Bratislava/Slovakia
 Mob. +420 775 757 225
 Tel. +421 2 5729 7421
 info@dex.sk
 www.dex.sk/ksr



WIKA Alexander Wiegand SE & Co. KG
 Alexander-Wiegand-Straße 30
 63911 Klingenberg/Germany
 Tel. +49 9372 132-0
 info@wika.de
 www.wika.de