

# SmartPurge® Z (SP Z)

# Zone 2

Fully Automatic Type Z Purge & Pressurization System  
for Zone 2 Gas Applications



Thank you for purchasing the SmartPurge® Z (SP Z). Scan the QR code to register your unit. By registering your product it will help Expo keep you up to date with the latest news and information about your SP Z.



# TABLE OF CONTENTS

- SECTION 1: SAFETY ..... 2**
  - 1.1: General Safety ..... 2
  - 1.2: Specific Conditions of Use ..... 2
- SECTION 2: APPLICATION SUITABILITY ..... 3**
- SECTION 3: INTRODUCTION ..... 3**
  - 3.1: Description ..... 3
  - 3.2: Main Components ..... 3
- SECTION 4: OPERATION ..... 6**
  - 4.1: General Principle ..... 6
  - 4.2: SP Z Operational Modes ..... 6
- SECTION 5: INSTALLATION ..... 8**
  - 5.1: Considerations ..... 8
  - 5.2: Dimensions ..... 9
  - 5.3: Mounting The System ..... 10
  - 5.4: Lid Removal/Replacement ..... 10
  - 5.5: Electrical Connection ..... 11
  - 5.6: Pneumatic Connection ..... 13
- SECTION 6: SYSTEM CONFIGURATION ..... 13**
  - 6.1: Set The Purge Timer ..... 13
- SECTION 7: SYSTEM START-UP / OPERATIONAL SEQUENCE ..... 13**
- SECTION 8: MAINTENANCE ..... 14**
- SECTION 9: TROUBLESHOOTING ..... 15**
- SECTION 10: RECOMMENDED SPARES ..... 16**
- SECTION 11: TECHNICAL SPECIFICATION ..... 16**
  - 11.1: Controller Specification ..... 16
  - 11.2: Model Numbers ..... 17



## SECTION 1: SAFETY

These operating instructions contain important information to ensure the safe installation and use of the Expo purge and pressurization system within the defined hazardous areas. Keep this manual in a safe place for future reference.

Only trained and authorized personnel should install, commission and maintain the purge system. Before any work commences the installer/operator should:

- Be knowledgeable of the safe working practices within the hazardous area where the system is to be installed.
- Familiar with the Expo system, certification requirements and any other relevant national laws and local legislation.
- Carefully read, understand and adhere to all instructions and warnings outlined in this manual.



**WARNING!** Installation, commissioning, maintenance, and troubleshooting must only be carried out by qualified and authorized personnel in accordance with local and site regulations.

### 1.1: GENERAL SAFETY

These safety instructions are intended to prevent equipment damage and/or personal injury.

- The system is to be used only in areas defined in this manual.
- The system must only be subject to temperatures as specified in this manual.
- The system must only be used for the purpose described in this manual.
- Each application requires different settings, it is the responsibility of the installer/operator to ensure the device matches the requirements of the certificate for the pressurized enclosure.
- Before any work commences of installation or maintenance always ensure the complete system, supply air/gas and electrical supplies are switched OFF, following safe isolation procedures.
- The system is to be inspected and maintained regularly as described in this manual.
- No unauthorised modifications to the equipment should be made.
- Purging and pressurization should be done in accordance with the relevant standard.

This document contains specific safety information you need to know for all stages of use of the product including installation, commissioning, operation, maintenance and troubleshooting.



**WARNING!** Failure to follow these instructions may impact the functionality and operation of the equipment, cause personal injury and/or cause an explosion.

### 1.2: SPECIFIC CONDITIONS OF USE

Potential electrostatic hazard, see instructions.

When polymeric cable gland is used on the side/external entry, the installation shall guarantee that the cable gland will be only exposed to a low risk of mechanical danger (< 4J impact).

When the SmartPurge Z is used with a pressurized enclosure, the assembly shall be evaluated according to the requirements of IEC 60079-0, IEC 60079-2 and IEC 60079-31, as applicable.



## SECTION 2: APPLICATION SUITABILITY

The SmartPurge Z (SP Z) pressurization system is certified for use in hazardous Zone 2 non-mining (above ground) areas with any flammable gases, or vapours.

This system is primarily designed for use with compressed air. Where other compressed inert gases are used such as nitrogen, the user must take suitable precautions to prevent build-up of the gas. Where a risk of asphyxiation exists, a warning label must be fitted to the system. Refer to the relevant material safety data sheet for more information.

The SP Z certification does not certify the enclosure the system is mounted on. The complete installation shall be evaluated to the appropriate standards and regulations applicable to the final installation location.

The SP Z has been constructed with materials suitable for the most common hazardous installation locations and is designed for use under normal industrial conditions of ambient temperature, humidity and vibration.

### Construction Materials

- Glass Reinforced Polycarbonate
- Polycarbonate
- Stainless Steel
- Silicone

**Note:** Please consult Expo for further guidance, if industrial conditions or the hazardous location may cause abnormal stresses or adversely affect the system.

## SECTION 3: INTRODUCTION

### 3.1: DESCRIPTION

The SP Z is a fully encompassed, electronic pressurization system uniquely housing the purge and pressurization control system, electrical connections and the relief valve (RLV) within a single GRP enclosure.





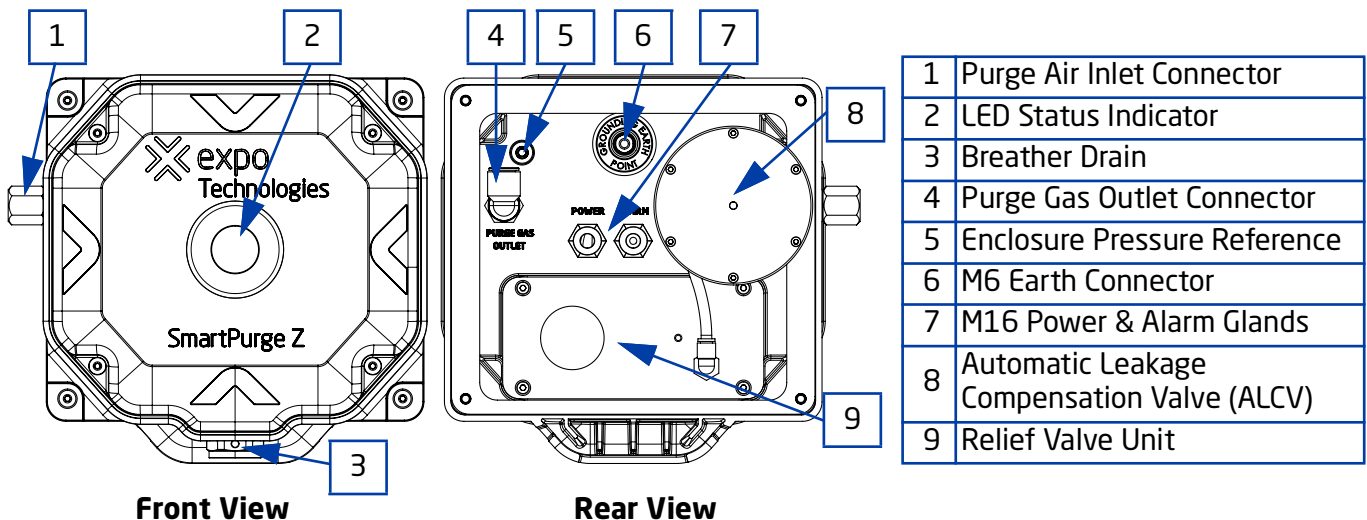

The SP Z has been designed to provide a fully automatic system switching between operating modes from purge mode to leakage compensation mode to alarm mode. An alarm contact allows for the provision of remote pressure status indication. The system offers a near plug-and-play solution for a purge system, ensuring easy installation and operation.

### 3.2: MAIN COMPONENTS







### 3.2.1: LED Status Indicator

The SP Z has 4 LEDs on the front of the unit to indicate the system status to the user.

LED Pattern		Description
	All Solid	Normal Operation, Enclosure Purged and Pressurized.
	All Flashing	System waiting Purge, Enclosure Pressurized (above minimum), Purge Flow is Too Low.
	Each Flashing*	Purging in Progress.
	Green flashing sequence	Purge Timer set to "00", Indefinite Purge Cycle.
	All Solid	Pressure Alarm. Low (below 0.5mbarg) or No Enclosure Pressure.
	All Flashing	System Fault. Refer to 4.2.3 Alarm mode - System Fault for more details.

\*Purge time is indicated sequentially by the 4 LEDs, each flashing in turn to indicate time complete.

			
0 to 25% of Time	26 to 50% of Time	51 to 75% of Time	76 to 100% of Time

### 3.2.2: Automatic Leakage Compensation Valve (ALCV)

After the purge cycle is completed, the system enters leakage compensation mode and the ALCV is active. The ALCV automatically adjusts the airflow as required up to 90NI/min (0.2 to 3.2SCFM) to maintain a stable enclosure pressure between 1.5 to 4.5mbarg (0.6 to 1.8"wc) after the purge cycle, compensating for any enclosure leakage.

### 3.2.3: Relief Valve Unit (RLV)

The RLV is built-in to the bottom of the housing of the SP Z. The RLV unit has two functions; a purge outlet valve and enclosure over pressure relief valve.

- During purging the RLV functions as a purge outlet valve and will be fully open to exhaust gases from the enclosure. The pressure inside the RLV is measured to confirm flow is correct during purging.
- During normal operation the RLV is closed. The RLV is pre-set to open if the enclosure pressure reaches 10mbarg (4"wc) to prevent over pressurization.

A spark arrestor is added to the exhaust point of the RLV to prevent the emission of arcs, sparks and incandescent particles that may be produced within the pressurized enclosure.

**Note:** It is important that the spark arrestor is kept clean and debris is not allowed to accumulate; this might affect the performance. In particular, the exterior of the spark arrestor should not be painted or blocked in any way.



**WARNING!** Ensure the exhaust gas can not contaminate the clean purge air supply.



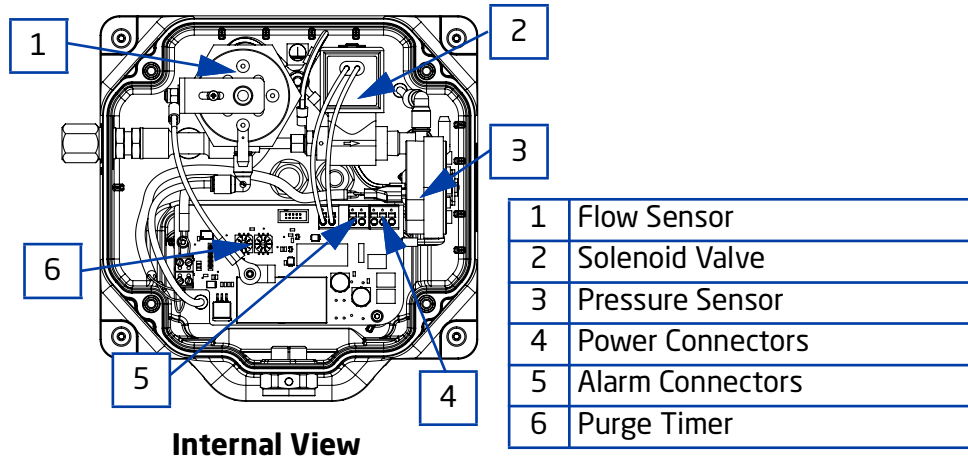

### 3.2.4: Flow Sensor

The flow sensor monitors the flow through the purge outlet valve. Once the set flow rate for purging is reached, the sensor sends a signal that activates the purge timer.

The flow sensor is factory calibrated to operate on a falling flow rate at or above the minimum specified purge flow rate.

### 3.2.5: Solenoid Valve

The solenoid valve supplies the purge air to the pressurized enclosure via the purge outlet connector during purge mode. It will only be open during purging and will close once the purge time is complete, directing all the incoming air through the ALCV.

### 3.2.6: Pressure Sensor

The pressure sensor monitors the pressure inside the pressurized enclosure via the enclosure pressure reference point on the rear of the SP Z. When the pressure is below the set pressure, the sensor will trigger pressure alarm mode.

The pressure sensor is factory calibrated and set to operate in falling pressure at or above 0.5mbar.

### 3.2.7: Alarm Signal Contact

The SP Z alarm signal, provided by a volt-free dry contact, can be used to provide remote indication. The contact is normally open

- Once the enclosure is pressurized and the purge time is complete, the alarm contact will close.
- If the enclosure pressure falls below the minimum enclosure pressure (0.5mbar), the alarm contact will open.

The user must make use of this alarm facility in accordance with the local code of practice for Action on Loss of Pressure. Most codes include the following recommendation for Zone 2 installations: Alarm Only, with power being removed manually.

### 3.2.8: Purge Timer

The purge timer ensures that the purge cycle lasts for the required purge time.

When the purge timer receives the signal from both the pressure and flow sensors, the purge timer will start, and the system will start the purge cycle.

The purge timer must be set by the end user via the two adjustment dials inside the SP Z, refer to commissioning for instructions.



## SECTION 4: OPERATION

### 4.1: GENERAL PRINCIPLE

Purge and pressurization is one of the most common methods of ignition protection which allows the installation and operation of electrical equipment that is not approved for use in hazardous areas. Purge and pressurization is a two-step process completed before electrical equipment inside an enclosure is energised.

During the initial purge process, clean compressed air or inert gas is supplied into the enclosure to displace any hazardous gas that has accumulated while the equipment was not pressurized. Once purged, the internal overpressure is maintained with the compressed air or inert gas. The overpressure prevents hazardous gas from the surrounding atmosphere from entering the enclosure.

After purging and pressurization, the interior of the enclosure is now a safe area, power can be turned on and any equipment/devices housed can be operated.

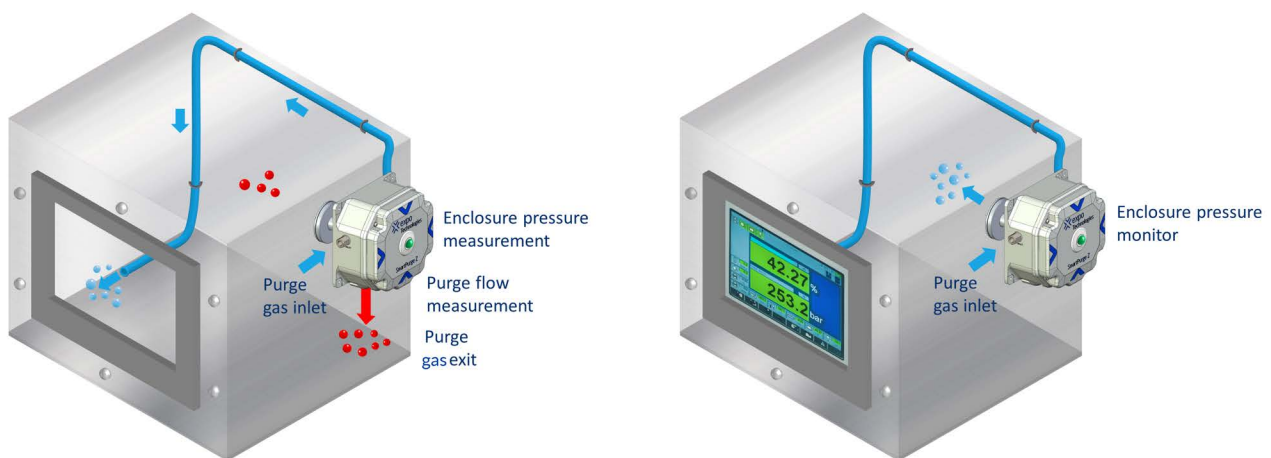

### 4.2: SP Z OPERATIONAL MODES

#### 4.2.1: Purge Cycle

During the purge cycle, the SP Z flushes the enclosure with clean air at the set flow to remove any contaminants within the enclosure. To ensure all areas of the enclosure are purged and only the clean purge air is left in the enclosure, the purge cycle must be set to allow multiple volume changes to take place. The minimum number of volume changes is 5 volume changes per IEC / EN 60079-2.

#### Purge Time

It is the user's responsibility to ensure the set purge time is adequate to "clean" the internal enclosure atmosphere. The required purge time can be calculated using the formula:

$$(\text{Enclosure Internal volume (L / ft.}^3) \times \text{No. Volume changes}) / \text{Purge Flow Rate (NI/min / SCFM)}$$

**Note:** Number of volume changes depends on certification requirements and the type of equipment contained within the enclosure. Refer to the pressurized enclosure certification.

**Note:** SP Z minimum purge flow rate is 310NI/min (11SCFM)

Scan the QR code to use the ExpoPurge Time Calculator to calculate your required purge time.





### 4.2.2: Normal Operation

At the end of the purge cycle, the SP Z automatically switches to leakage compensation mode. The air is directed through the ALCV which automatically adjusts the flow rate to account for any enclosure leakage up to 90NI/min (3.2SCFM) to maintain the required enclosure pressure.

Power to the electrical equipment inside the enclosure can be manually turned ON.

### 4.2.3: Alarm Mode

The SP Z has two alarm conditions, pressure and system faults.

#### Pressure Alarm

If pressure is lost within the enclosure, the SP Z will indicate the alarm via the LED turning solid Red. The alarm signal contact will open.

Once the enclosure pressure is re-established, the SP Z will automatically complete a purge cycle before commencing normal operation (leakage compensation mode).

#### System Fault

If the purge cycle is interrupted, the SP Z will attempt multiple times to complete the enclosure purge. Should the SP Z be unable to purge the enclosure after these attempts, the SP Z will indicate the fault with flashing Red LEDs. The alarm signal contact will remain open.

To reset the fault, power to the SP Z must be disconnected. Before reconnecting the power to the SP Z, check and resolve any issues causing the purge to fail, refer to troubleshooting.

**Note:** It is the user's responsibility to ensure power to the enclosure is turned OFF while the SP Z is in alarm mode and must not be reconnected until the SP Z has successfully completed a purge cycle.



## SECTION 5: INSTALLATION

### 5.1: CONSIDERATIONS

#### 5.1.1: Mounting

The SP Z should be installed such that the system indicators and certification labels are visible to the user.

#### 5.1.2: Air Supply

An external pressure regulator (not supplied) must be fitted to supply 4barg (58psig) to the SP Z.

**Note:** The optimal supply pressure for the SP Z to operate efficiently and minimise air consumption in Leakage Compensation mode is 4barg, but can still safely operate up to 5barg supply pressure.

The regulator must have the same, or larger, thread size as the SP Z inlet fitting (minimum 9mm inner diameter) should be fitted by the installer to prevent any restriction of the purge flow.

#### 5.1.3: Air Supply Quality

The SP Z should be connected to a protective air supply, which is suitable for purging and pressurization.

The air supply must be: clean, non-flammable and from a non-hazardous location. The air should be of Instrument Air Quality as defined by BS ISO 8573-1: 2010.

#### Particle Class 1

In each cubic metre of compressed air, the particulate count should not exceed 20,000 particles in the 0.1 to 0.5micron size range, 400 particles in the 0.5 to 1micron size range and 10 particles in the 1 to 5micron size range.

#### Humidity or pressure dew point

The dew point, at line pressure, shall be at least 10°C below the minimum locally recorded ambient temperature at the plant site. In no case, should the dew point at line pressure exceed 3°C.

#### Oil Class 2

In each cubic metre of compressed air, not more than 0.1mg of oil is allowed. This is a total level for liquid oil, oil aerosol and oil vapour.

**Note:** The system can operate with lower air quality, however the operational life of the SP Z and possibly the equipment being protected may suffer.

When an inert gas is being used to supply the purge system, the risk of asphyxiation exists.

#### 5.1.4: Compressed Air and Gas Safety

When handling compressed air/gas:

- Wear the appropriate personal protective equipment (PPE) for the task.
- Take precautions when connecting or disconnecting supplies.
- Ensure all pipe work and systems are well secured and are maintained in a good condition.
- Never block pipes with any part of the body.

#### 5.1.5: Pipework

The supply pipe connection to the SP Z must be appropriate for the maximum input flow rate.

The supply pipework should be flushed through with instrument quality air to remove any debris before connecting the pipes to the SP Z. This must be carried out for at least 10 seconds for every meter of pipe.

#### 5.1.6: Electric Connection

Cables into the enclosure must be through suitably Ex e cable glands.

If cable entries are not going to be used, the cable gland must be plugged with an Ex e blanking plug.



## 5.2: DIMENSIONS

### 5.2.1: System Dimensional Drawing

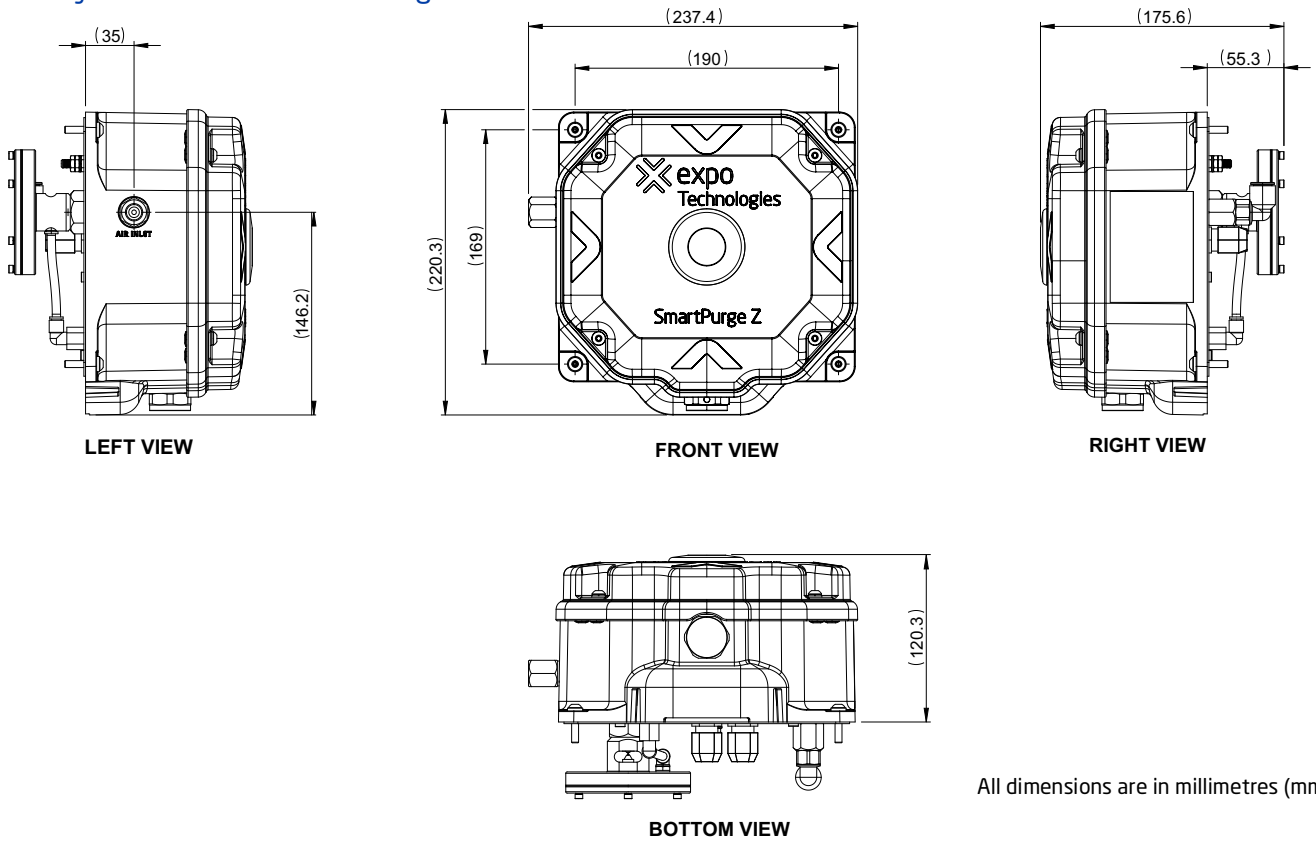

### 5.2.2: Panel Cut-out Drawing

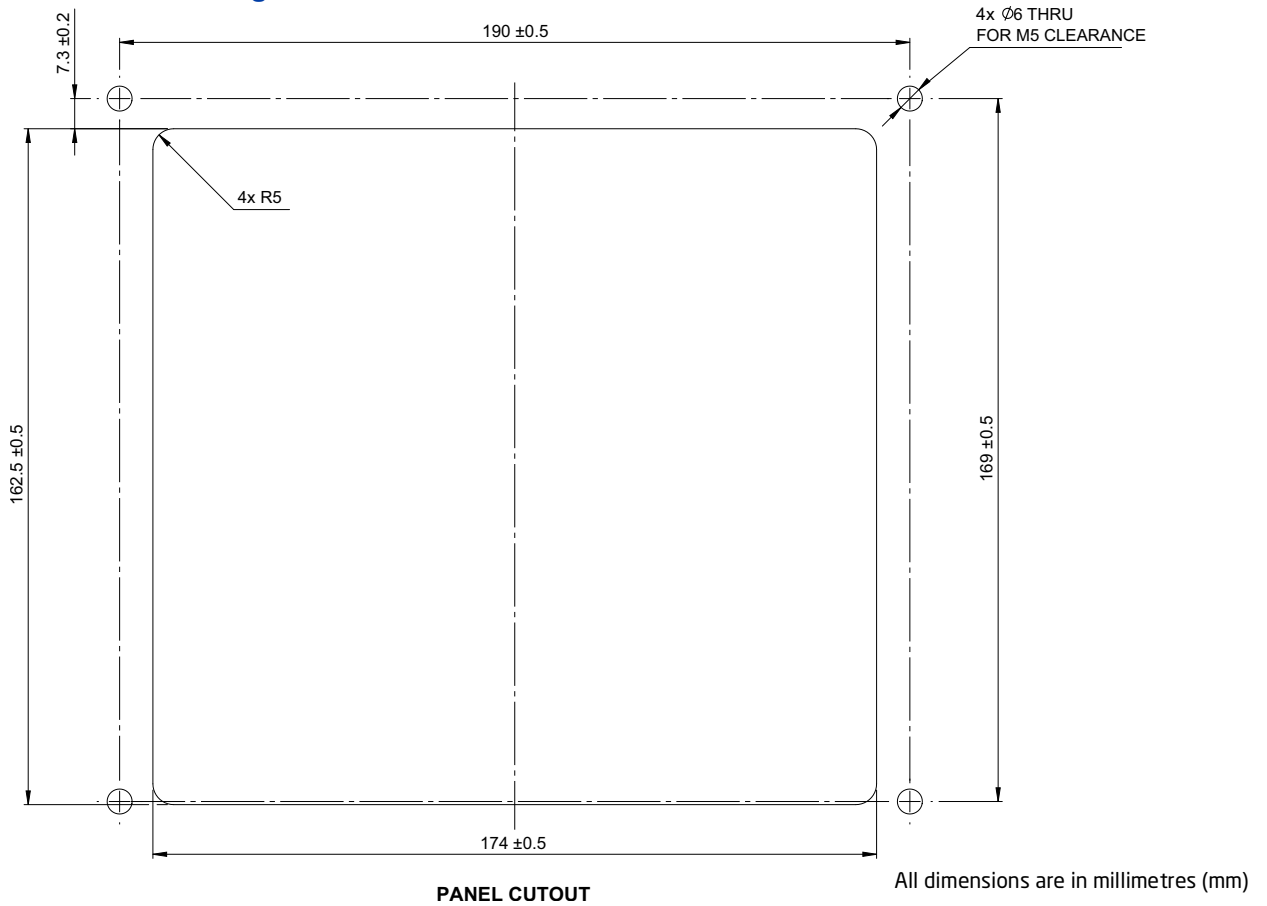

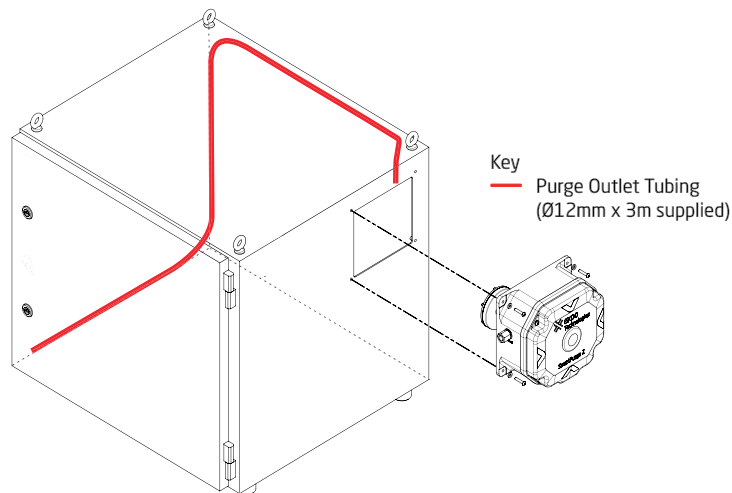

**Example of a Typical System Hook-up**

### 5.3: MOUNTING THE SYSTEM

- The SP Z shall only be installed vertically with the RLV at the bottom (Expo Technology logo the correct way around).
  - Allow a minimum clearance of 20mm (50mm recommended) around the RLV.
  - The ALCV sensing port (the small hole on the top of ALCV) must not be blocked/obstructed.
1. Cut the apertures within the enclosure as per the panel cut-out drawing and fix in place rivet nuts/nutserts (not supplied).
  2. Position the SP Z into place.
  3. Install the M5 mounting bolts and washers through the mounting holes in the SP Z into the enclosure.
  4. Tighten the bolts to secure in position to a torque of 2.9Nm to ensure an IP66 seal with the enclosure.

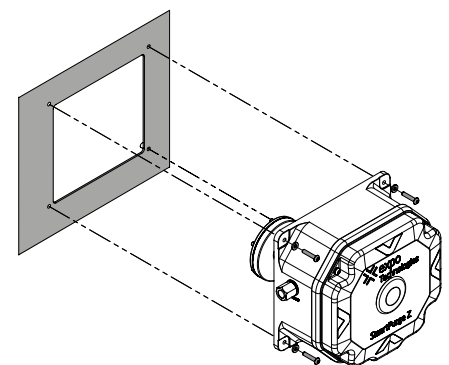
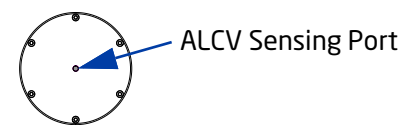

### 5.4: LID REMOVAL/REPLACEMENT



**WARNING!** The lid shall not be removed while the SP Z is energised.

1. Loosen the 4 retaining screws in the corners of the lid and lift to remove it.
2. Commence installation/set-up as required.

**Note:** The lid is attached to the SP Z enclosure via an anchor cord to prevent stress on electrical connections/wires. It is recommended the anchor cord is not unattached.

The lid forms an essentially part of the enclosure and care should be taken to make sure it is replaced fully. The lid has been designed to only fit one way.

3. Replace the lid ensuring the washers are still in place on each screw.
4. Tighten the screws to secure in place to a torque of 2.9Nm.

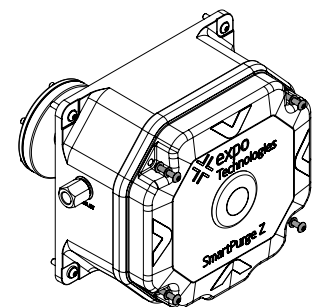

### 5.5: ELECTRICAL CONNECTION

- Installations shall comply with the relevant international/national standards for electrical installations such as IEC/EN 60079-14 or any other local codes of practice.
- Cables shall be suitably rated for the hazardous area of application.
- Power and Alarm cable glands are suitable for cables with an outer diameter ranging from 5 to 10mm.
- Conductor Cross Section 0.2 to 2.5mm<sup>2</sup> (AWG 24 to 14) shall be used for power and alarm connections.



**WARNING!** Cables are to be terminated within the SP Z ONLY. Care should be taken to ensure the wires are connected correctly and securely.

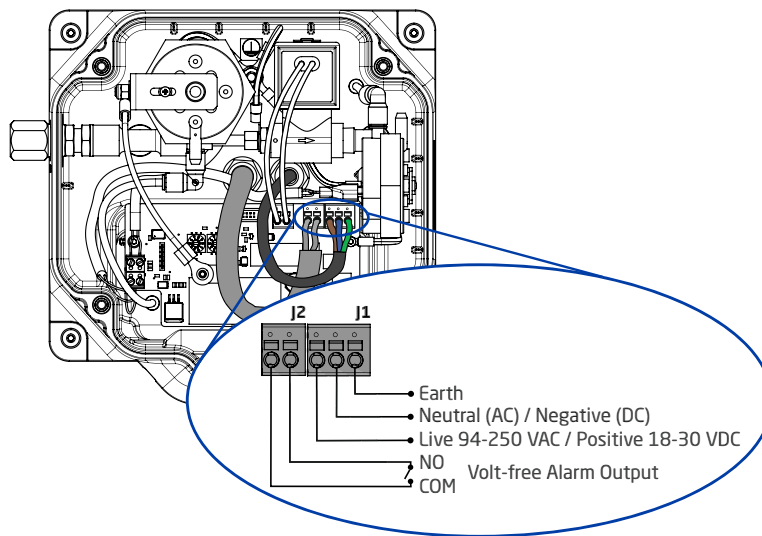

#### 5.5.1: Power Connection



**WARNING!** The SP Z requires power to operate. The power supply **MUST** be supplied from outside the enclosure since power needs to be applied before the purge cycle has complete.



**WARNING!** The power supply must not exceed the specification of the SP Z:  
Universal Voltage Model: 90 to 250VAC, 50 to 60Hz, 2A  
Low Voltage Model: 18 to 30VDC, 1.25A



**WARNING!** The power supply to the SP Z must be protected by a suitably rated circuit breaker.



**WARNING!** Take extra care to ensure the power cable is wired correctly to the SP Z terminals - potential risk of damage or electric shock if wired incorrectly.

It is recommended that the power supply to the SP Z have an external means of isolation. If placed in the hazardous area, it shall be approved for the area in which it is being installed.

1. Remove the lid to the SP Z.
2. Pass the power cable through the enclosure via a suitable cable gland.
3. Route the cable through the enclosure and into the power cable gland on the back of the SP Z.
4. Push the cable wires into the corresponding push-in terminals:
  - Universal Voltage Model: Live to L, Neutral to N, Earth to E.
  - Low Voltage Model: Positive (+) to L, Negative (-) to N.



5. Tighten the cable gland to hold the cable into position.
6. Replace the lid or proceed with alarm signal connection.

### 5.5.2: Alarm Signal Connection



**WARNING!** It is the responsibility of the user to ensure the alarm line is appropriately protected up to 16A inrush current.



**WARNING!** If the alarm signal connection is not required, the cable gland must be plugged.

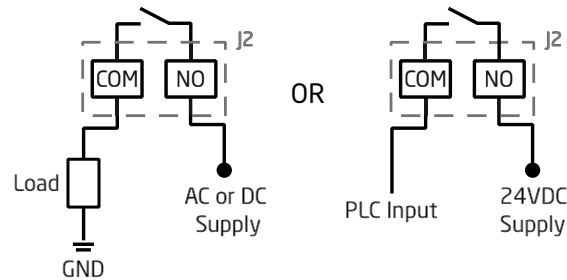

#### Typical Alarm Signal Hook-up

1. Pass the alarm signal cable through the enclosure via a suitable cable gland.
2. Route the cable through the enclosure and into the Alarm cable gland on the back of the SP Z.
3. Push the cable wires into the corresponding push-in terminal:
  - Supply (AC or DC) to NO
  - Output (load or PLC) to COM.
4. Tighten the cable gland to hold the cable into position.
5. Replace the lid.

**Note:** Before replacing the lid set the purge timer, refer to System Set-up.

### 5.5.3: Earth Connection



**WARNING!** The SP Z Must be earthed to the Enclosure and the Enclosure to the ground accordingly.



**WARNING!** The protective earth wire must be the same size as the largest wire used to bring power into the enclosure

The SP Z can be earthed using the M6 Earth stud on the back of the SP Z. The connection shall be a ring lug which is properly crimped and fully secured (2.5Nm torque) with anti-shake washers so it cannot be accidentally loosened.

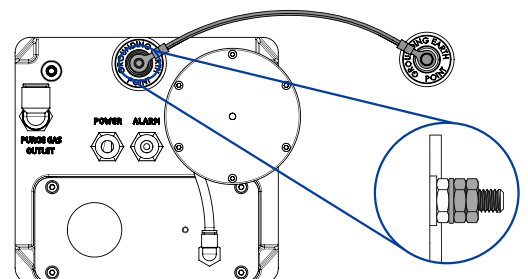

## 5.6: PNEUMATIC CONNECTION

- The Purge Air Inlet is a 1/4" NPT fitting so either a metal pipe can be mounted directly to the fitting or pneumatic plastic tubing (if appropriate for the application) can be fitted via an appropriate fitting/adaptor (not supplied) to a torque of 12Nm.
  - A minimum pipe inner diameter of 9mm must be used.
  - A regulator must be fitted to the inlet supply to ensure the SP Z receives 4barg.
1. Connect the supply line to the "Air Inlet" connector on the side of the SP Z.
  2. Inside the enclosure, connect the supplied 12mm tubing to the "Purge Gas Outlet" push-in connector on the rear of the SP Z.
  3. Route the tubing to the opposite side of the enclosure and cut to size. Secure the tube in position.

**Note:** To achieve effective purging, the points where air enters and exits the pressurized enclosure should be at opposite ends of the enclosure ensuring no dead spots.

## SECTION 6: SYSTEM CONFIGURATION

### 6.1: SET THE PURGE TIMER

Ensure power is isolated from the SP Z before adjusting the purge time.

1. Remove the lid.
2. Using a small flat screwdriver, rotate the dials on the main PCB according to the time required.
3. The left dial sets the tens, the right dial sets the unit. I.e. if 20 minutes is required, set the left dial to "2" and the right dial to "0".

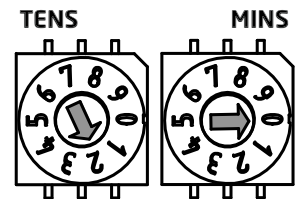

**Note:** Setting the timer to 00 minutes will cause infinite purging; the cycle will never complete.

4. Replace and secure the lid in position.

## SECTION 7: SYSTEM START-UP / OPERATIONAL SEQUENCE

After installation as outlined in section 5 and the system has been configured as required, system start-up can take place.



**WARNING!** Never turn the power ON to the SP Z whilst the lid is removed, unless the atmosphere is free of hazardous gas.

- Check all connections and the system has been installed as per this manual.
  - Check the "Purge Gas Outlet" tube has been routed correctly inside the enclosure.
  - Check the exit of the RLV is free from any obstructions.
  - Ensure the purge time has been set according to the requirement.
  - Check the SP Z is closed, with the lid secured in position.
1. Turn the power to the SP Z ON. The SP Z will enter low-pressure alarm mode, indicated by solid Red LEDs on the front of the unit.



2. Turn the air supply ON, ensuring the SP Z receives 4barg (58psig). The LEDs may momentarily flash Green to indicate the minimum enclosure pressure has been achieved, however the flow is insufficient for purging.

**Note:** 4barg is the optimal supply pressure for the SP Z to operate efficiently and minimise air consumption in Leakage Compensation mode. The SP Z can safely operate with a supply pressure of up to 5barg.

- If the enclosure pressure does not achieve minimum pressure, the SP Z will remain in alarm mode.
3. The purge flow must reach between 360 and 390NI/min (12.7 and 13.7SCFM) to trigger a purge cycle. During the purge cycle, at least the minimum purge flow rate of 310NI/min (11SCFM) must be maintained or the purge will stop. The purge time will be indicated by sequentially flashing Green LEDs.
    - If the purge time is set to "00" the system will purge indefinitely and will be indicated by flashing Green LEDs in sequence (infinite sign).
  4. Once the purge cycle is complete, the SP Z will enter leakage compensation mode, to maintain enclosure overpressure:
    - The LEDs will turn solid Green and the alarm signal contact will be closed.
    - Power to the enclosure can be manually turned ON.

**Alarm Check:** Reduce/turn OFF the air supply or open an enclosure door to create a low pressure alarm and check the alarm indication (Red LEDs) and the operation of the alarm signal contacts (if connected) when the enclosure pressure drops below the minimum pressure.

## SECTION 8: MAINTENANCE

The SP Z is designed to be maintenance-free, however, periodic checks shall be carried out on the complete system in compliance with the requirements of IEC 60079-17.

**Note:** Expo recommends that these tasks are carried out annually, however may be required more frequently depending on the environment.

- Check the SP Z housing is free from damage, and is adequately sealed (maintaining the required IP66)
- Labels are visible and legible.
- Power, alarm, and earthing cabling are connected and routed correctly, cables are free from damage and connections remain secure.
- Cable glands, conduit and other entry points are adequately sealed.
- All pipework is free from damage and securely connected.
- Check and remove any dust, dirt, or debris, especially around the RLV.
- Check the operation of the SP Z to ensure that the system generates an alarm when the enclosure pressure drops below 0.5mbarg (0.2"wc).
- Clean the SP Z housing with a damp cloth to prevent build up of static charge.





## SECTION 9: TROUBLESHOOTING

Problem	Possible Cause	Solution
Low enclosure pressure	No/low air supply	<ul style="list-style-type: none"> <li>• Turn the air supply ON.</li> <li>• Increase the air pressure.</li> <li>• Check the supply pipework for any blockages/holes.</li> </ul>
	Excessive leakage	<ul style="list-style-type: none"> <li>• Ensure all doors and covers are closed.</li> <li>• Ensure all glands/conduit are properly sealed.</li> <li>• Seal any other leaks.</li> </ul>
LEDs don't turn ON	No/wrong power supply	<ul style="list-style-type: none"> <li>• Turn the power supply ON.</li> <li>• Check the supply (AC/DC) matches the unit input voltage.</li> <li>• Check the supply voltage is within the operating range.</li> <li>• Check the supply wires are fully secure in the correct terminals.</li> </ul>
	Internal fuse blown	<ul style="list-style-type: none"> <li>• Contact Expo Technologies.</li> </ul>
	LED cable harness loose	<ul style="list-style-type: none"> <li>• Check the cable harness is fully secure in the connectors on the LED and main PCB.</li> </ul>
	LEDs/cable broken	<ul style="list-style-type: none"> <li>• Contact Expo Technologies.</li> </ul>
Purge won't start	Low air supply	<ul style="list-style-type: none"> <li>• Increase the air pressure/flow.</li> </ul>
	Sensor connectors loose	<ul style="list-style-type: none"> <li>• Check the electrical connections on the pressure/flow sensors are fully secure.</li> <li>• Check sensor connections on the main PCB (J3 &amp; J4) are fully secure.</li> </ul>
	Purge outlet valve faulty	<ul style="list-style-type: none"> <li>• Contact Expo Technologies.</li> </ul>
Purge starts but does not complete	Air supply drops during purging	<ul style="list-style-type: none"> <li>• Turn the air pressure/flow UP to compensate for any drop.</li> </ul>
System purges but trips to re-purge	Pressure sensor drifted from calibrated value	<ul style="list-style-type: none"> <li>• Contact Expo Technologies.</li> </ul>
Purge will not complete	Timer set to "00"	<ul style="list-style-type: none"> <li>• Set the purge timer as required.</li> </ul>

If the SP Z is still not performing as it should, or you have another issue, contact Expo Technologies.



## SECTION 10: RECOMMENDED SPARES

Part Number	Description	Quantity
KGM-SP00-044	SmartPurge Z Spare Parts Kit - including: Mounting screws and washers, Lid fixing screws and washer, Lid gasket & Enclosure Gasket	1



**WARNING!** There are no internal serviceable parts in the SP Z. Under no circumstances shall any components be dismantled or removed from the unit.



**WARNING!** Access inside the SP Z shall only be for the purposes described in this manual. Repairs can only be performed by an Expo trained service and authorised engineer. Contact Expo Technologies.

Only the replacement of parts within the spare parts kit are permitted by the user, consult Expo if other spares or parts require replacement.

## SECTION 11: TECHNICAL SPECIFICATION

### 11.1: CONTROLLER SPECIFICATION

Operation Mode	Automatic Leakage Compensation				
Purge Gas	Compressed Air or Inert Gas				
Air Supply Pressure	Regulated supply 4 barg (58 psig), regulator not supplied Maximum 5 barg (72 psig)				
Minimum Purge Flow Rate	Minimum 310 NI/min (11 SCFM) @ 4 barg supply pressure				
Leakage Compensation Capacity	Up to 90 NI/min (Up to 3.2 SCFM)				
Relief Valve	Integrated into the unit Lift-Off Pressure: 10 mbarg (4"wc)				
Enclosure Pressure	1.5 to 4.5 mbarg (0.6 to 1.8"wc) after purge				
Minimum Enclosure Pressure	0.5 mbarg (0.2"wc)				
Action on Pressure Failure	Alarm only				
Power Supply	<table border="0"> <tr> <td>Universal Voltage Model</td> <td>90 to 250 VAC, 50 to 60 Hz, 60 mA @ 230 VAC, Um = 250 VAC Internal Fuse Rating: 2 A Power Consumption: 13.8 W (Purging) ; 2.8 W (Standby)</td> </tr> <tr> <td>Low Voltage Model</td> <td>18 to 30 VDC, 300 mA @ 24 VDC, Um = 30 VDC Internal Fuse Rating: 1.25 A Power Consumption: 7.2 W (Purging) ; 1.0 W (Standby)</td> </tr> </table>	Universal Voltage Model	90 to 250 VAC, 50 to 60 Hz, 60 mA @ 230 VAC, Um = 250 VAC Internal Fuse Rating: 2 A Power Consumption: 13.8 W (Purging) ; 2.8 W (Standby)	Low Voltage Model	18 to 30 VDC, 300 mA @ 24 VDC, Um = 30 VDC Internal Fuse Rating: 1.25 A Power Consumption: 7.2 W (Purging) ; 1.0 W (Standby)
Universal Voltage Model	90 to 250 VAC, 50 to 60 Hz, 60 mA @ 230 VAC, Um = 250 VAC Internal Fuse Rating: 2 A Power Consumption: 13.8 W (Purging) ; 2.8 W (Standby)				
Low Voltage Model	18 to 30 VDC, 300 mA @ 24 VDC, Um = 30 VDC Internal Fuse Rating: 1.25 A Power Consumption: 7.2 W (Purging) ; 1.0 W (Standby)				
Over Voltage Protection	Category II (IEC 61010-1)				
Alarm Signal Output (Remote Indication)	Normally Open Volt-Free Dry Contact AC-1 250 VAC, 8 A, DC-1 30 VDC, 6 A The relay must be externally fused inrush current: 16 A				



LED Status Indicator	Green: Purging Status Red: Alarm / Fault
Purge Time	User selectable 1 to 99 minutes (-0, +3 seconds) Default set to 99 minutes
Process Connections	Purge Air Inlet: 1/4" NPT Purge Gas Outlet: 12 mm push fitting - 3 m (10 ft) tube supplied
Power and Alarm Connections	Push-in Terminal Block - 24 to 14 AWG wire size
Cable Glands	M16 suitable for cable Ø5 to 10 mm
Earth Connection	M6 Stud
Mounting Method	Direct mounting to an enclosure wall 4x M5 bolts (Supplied) ; nuts not provided
Material	Glass Reinforced Polycarbonate
Impact Protection	IK10
Ingress Protection	IP66
Noise Level	75 db
Operating Temperature	-20 to +58°C (-4 to +136°F)
Relative Humidity	<95%
Storage & Transport Temperature	-20 to +58°C (-4 to +136°F)
Unit Dimensions (LxWxD)	237.4 x 220.3 x 175.6 mm (9.35 x 8.67 x 6.91") Depth outside the pressurized enclosure: 120.3 mm (4.74")
Unit Weight	3 kg
Supplementary Information	EU Declaration of Conformity
Certification	ATEX ExVeritas 24ATEX1788X ⊕ II 3 (3) G Ex ec ic nC [pzc Gc] IIC T5 Tamb -20 to +58°C
	IECEX IECEX EXV 24.0015X Ex ec ic nC [pzc Gc] IIC T5 Tamb -20 to +58°C

**Note:** A Declaration of Conformity is included with these instructions. The latest certificates and Declaration of Conformity can be requested from Expo Technologies or local distributors or downloaded from [www.expoworldwide.com](http://www.expoworldwide.com).

## 11.2: MODEL NUMBERS

### SPZ-1ALG-x111

x = Electrical Supply

L = Low Voltage Input

M = Universal Voltage Input





**EU Authorised Representative:**  
ExpoPharma Engineering Services Ltd  
46 Eastcote Drive, Little Island,  
Co. Cork, T45 WR68, Ireland.  
Email: EUAR@expopharma.ie

**Manufacturer:**  
Expo Technologies Ltd  
Unit 2, The Summit, Hanworth Road,  
Sunbury-on-Thames, TW16 5DB, U.K.  
Email: sales@expoworldwide.com

# EU Declaration of Conformity



This declaration of conformity is issued under the sole responsibility of the manufacturer named above:

## Object of the declaration:

<b>Product Name:</b>	SmartPurge Z Purge Control Unit (SPZ)
<b>Product Options:</b>	This declaration covers all variants associated with the above product

The object of the declaration described above is in conformity with the relevant Union harmonization legislation:

<b>Type of Legislation:</b>	
	Electromagnetic Compatibility Directive 2014/30/EU
	ATEX Directive 2014/34/EU

The following harmonised standards and technical specifications have been applied:

Type of Legislation:	General Standard:	Reference Standard:
<b>EMC Directive:</b>	Electromagnetic compatibility (EMC) - Generic standards Immunity standard for industrial environments	EN 61000-6-2:2019
	Electromagnetic compatibility (EMC) - Generic standards Emission standard for industrial environments	EN 61000-6-4:2019
<b>ATEX Directive:</b>	Equipment general requirements	EN IEC 60079-0:2018
	Equipment protection by pressurized enclosure "p"	EN 60079-2:2014
	Equipment protection by increased safety "e"	EN 60079-7:2015+2018
	Equipment protection by intrinsic safety "i"	EN 60079-11:2012
	Equipment protection by type of protection "n"	EN 60079-15:2019
<b>Ingress Protection:</b>	Equipment dust ignition protection by enclosure "t"	EN 60079-31:2014
	Degrees of protection provided by enclosures (IP code)	EN 60529:1992+A2:2013

## Notified Body:

<b>NB Name:</b>	ExVertias
<b>NB Number:</b>	2804

Technical documentation and assessments are in the Expo Technologies Ltd confidential technical file SC050.

For and on behalf of Expo Technologies Ltd.

John Paul De Beer  
Managing Director

**Date:** 16<sup>th</sup> August 2024

SC050 EU DoC SmartPurgeZ Iss. 1





**This page left intentionally blank**



**This page left intentionally blank**





# Simplifying Complexity. Delivering Safety



## **Expo Technologies UK**

Expo Technologies Ltd.  
Unit 2 The Summit, Hanworth Road  
Sunbury-on-Thames,  
TW16 5DB, UK  
T: +44 20 8398 8011  
E: sales@expoworldwide.com



## **EU-Authorised Representative**

Expo Pharma Engineering  
Unit 46, Eastgate Drive  
Little Island, Co. Cork  
T45 WR6, Ireland  
E: euar@expopharma.ie



## **Expo Technologies Germany**

Johannstraße 37, 3rd Floor  
40476 Düsseldorf  
T: +49 (0) 211 54085105  
E: sales@expoworldwide.com



## **Expo Technologies USA**

Expo Technologies Inc.  
9140 Ravenna Road Unit #3  
Twinsburg,  
OH 44087, USA  
T: +1 440 247 5314  
E: sales.na@expoworldwide.com



## **Expo Technologies China**

Qingdao Expo M&E Technologies Co. Ltd  
617 Shilin Er Lu  
Jimo District, Qingdao,  
266200, China  
T: +86 532 8906 9858  
E: qingdao@expoworldwide.com