

Reed level transmitter Model FLR-SBDF

WIKA data sheet LM 20.14



For further approvals,
see page 4



Applications

- Level detection for liquid media
- Chemical, petrochemical industry, natural gas, offshore, machine building, power generating equipment, power plants, pipeline compressors
- Suitable for use in hazardous areas

Special features

- Process temperature range -40 °C ... +150 °C [-40 °F ... +302 °F]
- Case made of epoxy-resin-coated cast aluminium or of stainless steel
- Version with or without display
- Combined ATEX Ex d approval with ETL listing
- Compact float design for small process connections



Level transmitter, model FLR-SBDF

Description

The model FLR level transmitters with reed measuring chain are used for level measurement in liquid media. They work on the float principle with magnetic transmission.

The float's magnetic system in the guide tube actuates a resistance measuring chain that corresponds to a 3-wire potentiometer circuit.

The measuring voltage generated by this is proportional to the fill level. The measuring voltage is very finely stepped due to the contact separation of the measuring chain and is thus virtually continuous. Depending on the requirements, several different contact separations are available.

Specifications

Functionality

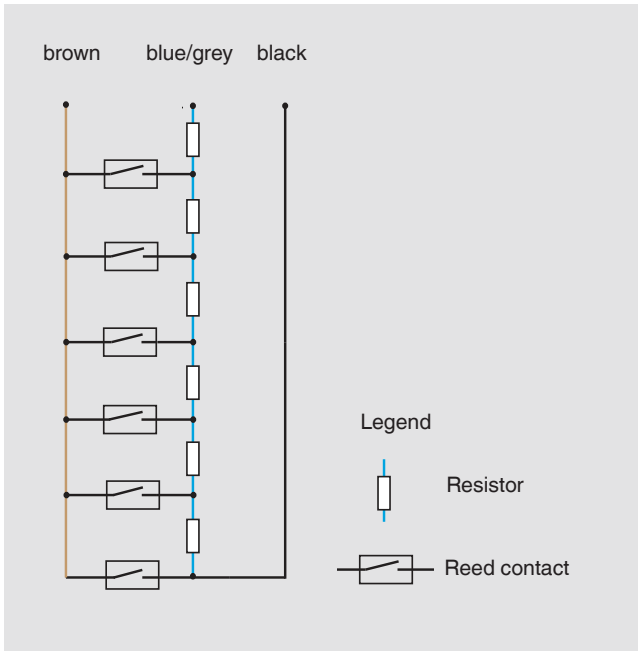

Advantages of 3-wire potentiometer measuring:

- Temperature compensation by measuring partial resistance to overall resistance: If the resistors are heated evenly, the ratio between the overall resistance and the partial resistance remains the same. This therefore has no effect on the measuring deviation.
- Easier error detection when installed: By measuring the overall resistance, a possible fault can be detected as soon as it occurs.

Basic information	
Measurement principle	Reed-chain technology
Guide tube length L	<ul style="list-style-type: none"> ■ 3,000 mm [118.11 in] (guide tube diameter 12 mm [0.47 in]) ■ 3,500 mm [137.8 in] (guide tube diameter 14 mm [0.55 in]) ■ 6,000 mm [236.22 in] (guide tube diameter 18 mm [0.71 in])
Guide tube diameter	<ul style="list-style-type: none"> ■ 12 mm [0.47 in] ■ 14 mm [0.55 in] ■ 18 mm [0.71 in]
Accuracy, resolution	<ul style="list-style-type: none"> ■ 2.7 mm [0.11 in] with 5 mm [0.2 in] contact separation ■ 5.5 mm [0.22 in] with 10 mm [0.39 in] contact separation ■ 7.5 mm [0.3 in] with 15 mm [0.59 in] contact separation ■ 9 mm [0.35 in] with 18 mm [0.71 in] contact separation
Transmitter	Digital transmitter model T32, head-mounted version → See data sheet TE 32.04
Case cover	Removable with stainless steel chain

Scale range	
Digital indicator	
Display range	7 segments
Type of display	LCD
Character size	9 mm [0.35 in]
Digits	5-digit
Bar graph display	20 individual segments

Process connection	
Thread size / Size	
Mounting thread downwards	<ul style="list-style-type: none"> ■ G ½ ... G2 ■ ½ NPT ... 2 NPT
Mounting flange	<ul style="list-style-type: none"> ■ DIN DN 50 ... DN 200, PN 6 ... PN 100 ■ ANSI 2 ... 8, Class 150 ... 600

Materials		
Case	Aluminium, powder-coated	<ul style="list-style-type: none"> ■ Window ■ Blind cover
	Stainless steel 1.4571, unpainted	<ul style="list-style-type: none"> ■ Window ■ Blind cover
Process connection	Stainless steel 1.4571	
Guide tube	Stainless steel 1.4571	
Float	→ See float table on page 6	
Float limitation	Stainless steel 1.4571	

Output signal		
Variable resistance	The overall resistance of the reed chain is approx. 1 ... 10 kΩ, depending on the measuring range	
Current output		
Analogue output (configurable)	<ul style="list-style-type: none"> ■ 4 ... 20 mA, 2-wire ■ 20 ... 4 mA, 2-wire 	
Auxiliary power	DC 14.5 ... 29 V, max. 130 mA	
Load	→ See data sheet TE 32.04	
Output limits (configurable)		
In accordance with NAMUR NE43	Lower limit	3.8 mA
	Upper limit	20.5 mA
Simulation	In simulation mode, independent from input signal, simulation value configurable from 3.5 ... 23.0 mA	
Current value for error signalling		
In accordance with NAMUR NE43	Downscale	< 3.6 mA (3.5 mA)
	Upscale	> 21.0 mA (21.5 mA)
Setting range (customer-specific)	Downscale	3.5 ... 3.6 mA
	Upscale	21.0 ... 22.5 mA
Communication		
Communication protocol	HART® protocol rev. 5 including burst mode, multidrop	
	HART® protocol rev. 7 including burst mode, multidrop	

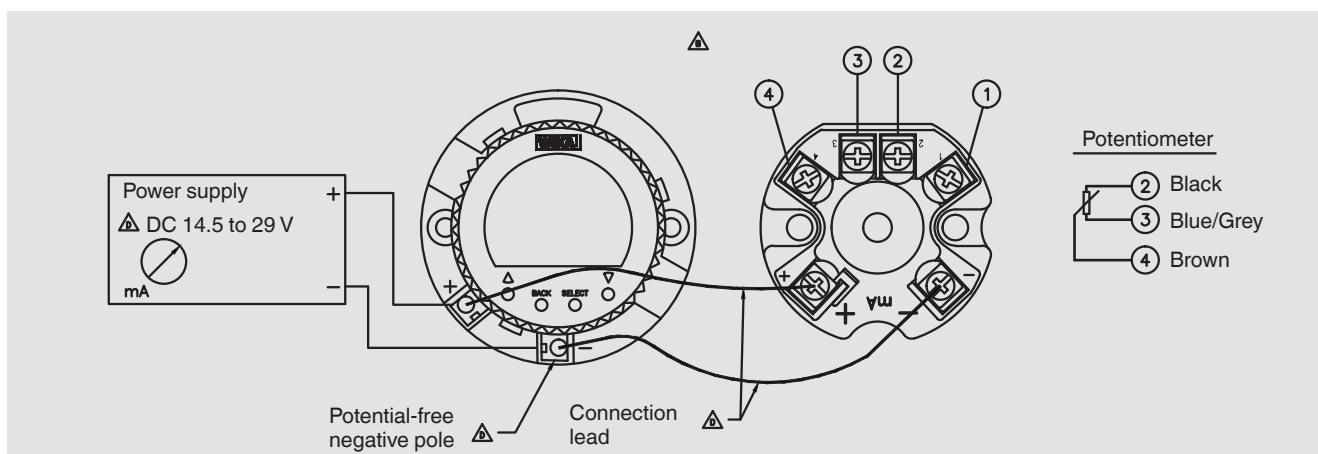

Electrical connection	
Connection type	Cable
Cable bushing	¾ NPT
Connection cable to transmitter	2-wire, shielded
Ingress protection / IP code	<ul style="list-style-type: none"> ■ IP66 per IEC/EN 60529 ■ NEMA 4X

Electrical connection between display and transmitter





Operating conditions	
Process temperature	-40 ... +150 °C [-40 ... +302 °F]
Ambient temperature range	-50 ... +60 °C [-58 ... +140 °F]
Storage temperature range	-40 ... +80 °C [-40 ... +176 °F]
Max. operating pressure	80 bar [1,160.3 psij]
Mounting position	Vertical ± 30°
Permissible pollution degree	3 per EN 61010-1

Approvals

Logo	Description	Region
	EU declaration of conformity	European Union
	EMC directive EN 61326 emission (group 1, class B) and immunity (industrial environments)	
	Hazardous areas	
	RoHS directive	
	UKCA	United Kingdom
	Electromagnetic compatibility regulations	
	Restriction of Hazardous Substances (RoHS) regulations	
	Equipment and protective systems intended for use in potentially explosive atmospheres regulations	

Optional approvals

Logo	Description	Region
	EU declaration of conformity	European Union
	ATEX directive Hazardous areas - Ex d Zone 1 gas II 2G Ex d IIC T6 Gb Temperature class Max. process temperature T6 70 °C [158 °F] T5 85 °C [185 °F] T5 120 °C [248 °F] T3 149 °C [300 °F]	
	ETL listed Hazardous areas	
	Class I division 1, groups B, C, D, T3 ... T6 Class II division 1, groups E, F, G, T3, T4, T5, T6 Standards <ul style="list-style-type: none"> ■ Safety Requirements For Electrical Equipment For Measurement, Control, And Laboratory Use - Part 1: General Requirements [UL 61010-1:2012 Ed.3 +R:15Jul2015] ■ Safety Requirements For Electrical Equipment For Measurement, Control, And Laboratory Use – Part 1: General Requirements [CSA C22.2#61010-1-12:2012 Ed.3+U1] ■ FM 3600 Issue:2011/12/01 Electric Equipment for Use in Hazardous (Classified) Locations – General Requirements ■ FM 3615 Issued: 2006/08/01 Explosionproof Electrical Equipment General Requirements ■ CSA C22.2#30 Issued: 1986/11/01 (R2012) Explosion-Proof Enclosures for Use in Class I Hazardous Locations General Instruction No. 1, 1986, General Instruction No. 2, 1988 ■ FM 3616 Issued: 2011/12/01 Dust - Ignitionproof Electrical Equipment - General Requirements ■ CSA C22.2#25 Issued: 1966/09/01 (R2014) Enclosures for Use in Class II Groups E, F, and G Hazardous Locations; Gen. Inst. No. 1: 1966 	

Certificates

Certificates	
Certificates	<ul style="list-style-type: none"> ■ 2.2 test report per EN 10204 (e.g. state-of-the-art manufacturing, material proof, indication accuracy) ■ 3.1 inspection certificate per EN 10204 (e.g. material proof for wetted metal parts, indication accuracy, calibration certificate)

→ For approvals and certificates, see website

Dimensions in mm [in]

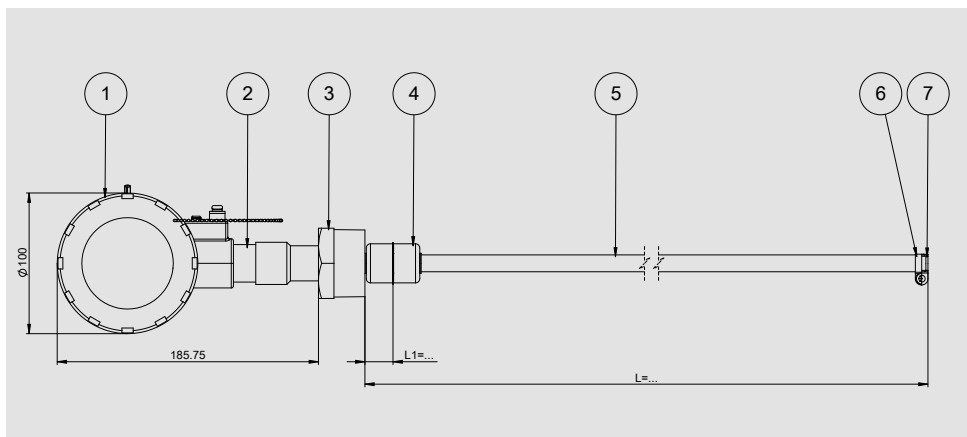

- ① Case
- ② Support
- ③ Plug
- ④ Float
- ⑤ Guide tube
- ⑥ Float strap (float limitation)
- ⑦ Pipe cap

Float

Spherical float

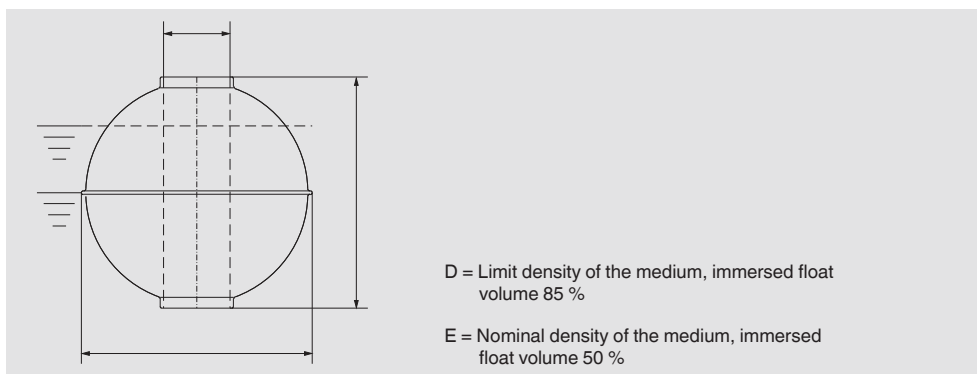

Material	Version	Guide tube diameter \varnothing in mm [in]	\varnothing A in mm [in]	B in mm [in]	\varnothing C in mm [in]	Max. operating temp. in °C	Limit density 85 % in kg/m ³	Order no.
Stainless steel 1.4571	V29A/40	12 [0.47]	29 [1.14]	40 [1.58]	13 [0.51]	180	720	030352
	V52R	12 [0.47]	52 [2.05]	52 [2.05]	15 [0.59]	250	720	020913
	V62R	12 [0.47]	62 [2.44]	61 [2.4]	15 [0.59]	250	670	026026
	V83R	12 [0.47]	83 [3.27]	81 [3.19]	15 [0.59]	250	430	021089
	V80R	18 [0.71]	80 [3.15]	76 [2.99]	23 [0.91]	250	630	005479
	V98R	18 [0.71]	98 [3.86]	96 [3.78]	23 [0.91]	250	600	005490
	V105R	18 [0.71]	105 [4.13]	103 [4.06]	23 [0.91]	250	560	005494
	V120R	18 [0.71]	120 [4.72]	117 [4.61]	23 [0.91]	250	470	026726
	V120R	18 ... 30 [0.71 ... 0.18]	120 [4.72]	116 [4.57]	38 [1.5]	250	537	-
	V200R	18 ... 30 [0.71 ... 0.18]	200 [7.87]	192 [7.56]	56 [2.21]	250	581	005503
	V300R	18 ... 30 [0.71 ... 0.18]	300 [11.81]	294 [11.58]	56 [2.21]	250	342	-
Titanium 3.7035	T52R	12 [0.47]	52 [2.05]	52 [2.05]	15 [0.59]	250	680	026655
	T52R	12 [0.47]	52 [2.05]	52 [2.05]	15 [0.59]	250	810	034037
	T52R	12 [0.47]	52 [2.05]	52 [2.05]	15 [0.59]	250	957	122702
	T62R	12 [0.47]	62 [2.44]	62 [2.44]	15 [0.59]	250	390	005538
	T83R	12 [0.47]	83 [3.27]	81 [3.19]	15 [0.59]	250	350	005544
	T80R	18 [0.71]	80 [3.15]	76 [2.99]	23 [0.91]	250	670	005543
	T105R	18 [0.71]	105 [4.13]	103 [4.06]	23 [0.91]	250	440	005549
	T120R	18 [0.71]	120 [4.72]	117 [4.61]	23 [0.91]	250	480	115002

Cylindrical float

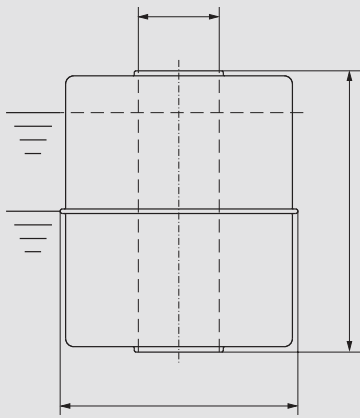

D = Limit density of the medium, immersed float volume 85 %

E = Nominal density of the medium, immersed float volume 50 %



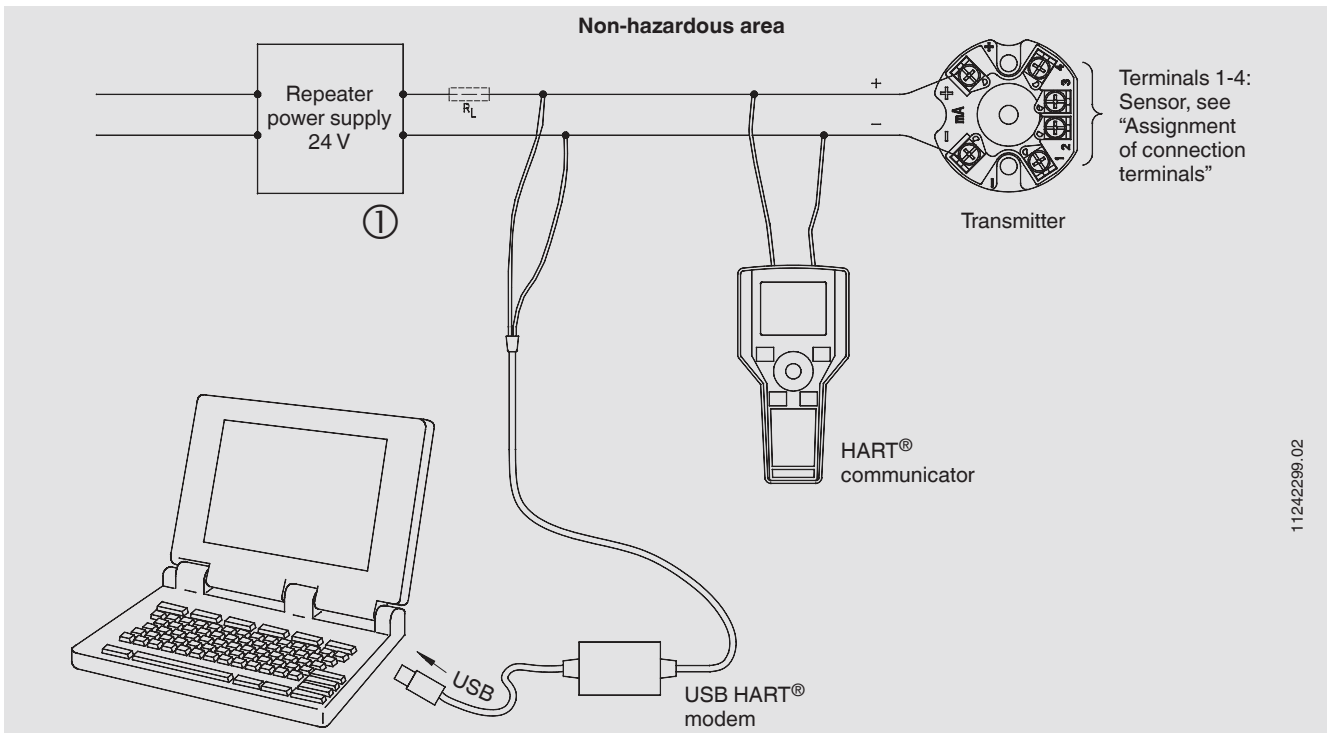

Material	Version	Guide tube diameter \varnothing in mm	\varnothing A in mm	B in mm	\varnothing C in mm	Max. operating temp. in $^{\circ}$ C	Limit density 85 % in kg/m^3	Order no.
Stainless steel 1.4571	V27A	8 [0.32]	27 [1.06]	31 [1.22]	10 [0.39]	16	787	009679
	V44R	12 [0.47]	44 [1.73]	52 [2.05]	15 [0.59]	16	780	034196
Titanium 3.7035	T44R	12 [0.47]	44 [1.73]	52 [2.05]	15 [0.59]	16	550	022639

Configuration

Typical connection in non-hazardous area



Accessories and spare parts

Model	Description	Order number
Programming unit, model PU-H		
	VIATOR® HART® USB	HART® modem for USB interface 11025166
	VIATOR® HART® USB PowerXpress™	HART® modem for USB interface 14133234
	VIATOR® HART® RS-232	HART® modem for RS-232 interface 7957522
	VIATOR® HART® Bluetooth® Ex	HART® modem for Bluetooth interface, Ex 11364254
	Magnetic quick connector, model magWIK	<ul style="list-style-type: none"> ■ Replacement for crocodile clips and HART® terminals ■ Fast, safe and tight electrical connection ■ For all configuration and calibration processes 14026893

Ordering information

Model / Version / Electrical connection / Process connection / Guide tube diameter / Guide tube length (insertion length) L / Contact separation / 100 % mark L₁ / Measuring range M (span 0 ... 100 %) / Process specifications (operating temperature and pressure, limit density) / Options

© 06/2024 WIKA Alexander Wiegand SE & Co. KG, all rights reserved.
The specifications given in this document represent the state of engineering at the time of publishing.
We reserve the right to make modifications to the specifications and materials.
In case of a different interpretation of the translated and the English data sheet, the English wording shall prevail.



D-Ex Instruments, s.r.o.
Optátova 708/37
637 00 Brno/Czech Republic
Mob. +420 775 757 225
Tel. +420 541 423 225
ksr@dex.cz
www.dex.cz/ksr



D-Ex Instruments, s.r.o.
Pražská 3222/1
811 04 Bratislava/Slovakia
Mob. +420 775 757 225
Tel. +421 2 5729 7421
info@dex.sk
www.dex.sk/ksr



WIKA Alexander Wiegand SE & Co. KG
Alexander-Wiegand-Straße 30
63911 Klingenberg/Germany
Tel. +49 9372 132-0
info@wika.de
www.wika.de