

**768 LN
MALE PIPE WELD
CONNECTOR**

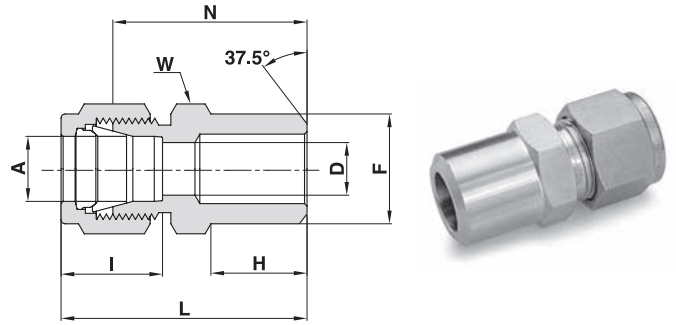

TUBE (METRIC)									
Ordering Information	A	F		D	W	N	H	L	I
	Tube O.D.	Pipe Size			Hex. Flat				
	mm	inch	mm	mm	mm	mm	mm	mm	mm
768LN _ 3 X 1/8	3	1/8	10.30	2.4	12	23.9	9.7	30.5	12.9
768LN _ 4 X 1/8	4	1/8	10.30	2.4	12	24.6	9.7	31.2	13.7
768LN _ 6 X 1/8	6	1/8	10.30	4.8	14	25.4	9.7	32.8	15.3
768LN _ 6 X 1/4	6	1/4	13.70	4.8	14	30.5	14.2	37.9	15.3
768LN _ 8 X 1/8	8	1/8	10.30	5.1	15	26.7	9.7	34.2	16.2
768LN _ 8 X 1/4	8	1/4	13.70	6.4	15	31.2	14.2	38.7	16.2
768LN _ 8 X 1/2	8	1/2	21.34	6.4	22	38.1	19.0	45.6	16.2
768LN _ 10 X 1/4	10	1/4	13.70	7.1	18	33.3	14.2	40.9	17.2
768LN _ 10 X 3/8	10	3/8	17.10	7.9	18	33.3	14.2	40.9	17.2
768LN _ 10 X 1/2	10	1/2	21.34	7.9	22	38.9	19.0	46.5	17.2
768LN _ 12 X 1/4	12	1/4	13.70	7.1	22	33.3	14.2	43.4	22.8
768LN _ 12 X 3/8	12	3/8	17.10	9.5	22	33.3	14.2	43.4	22.8
768LN _ 12 X 1/2	12	1/2	21.34	9.5	22	38.9	19.0	49.0	22.8
768LN _ 12 X 3/4	12	3/4	26.67	9.5	27	40.4	19.0	50.5	22.8
768LN _ 14 X 3/8	14	3/8	17.10	10.4	24	34.0	14.2	44.1	24.4
768LN _ 15 X 1/2	15	1/2	21.34	11.9	24	38.9	19.0	49.0	24.4
768LN _ 16 X 1/2	16	1/2	21.34	12.7	24	38.9	19.0	49.0	24.4
768LN _ 18 X 1/2	18	1/2	21.34	13.5	27	40.4	19.0	50.5	24.4
768LN _ 38 X 1 1/2	*38	1 1/2	48.30	33.7	55	64.0	26.2	91.2	49.4

Designation: Marking LN on Hex.
* Including low friction paste, see page 91

"D" - Dimension is minimum opening. Dimensions are for reference only, and are subject to change without notice.

Cont'd next page

768 LN MALE PIPE WELD CONNECTOR

(Cont'd)

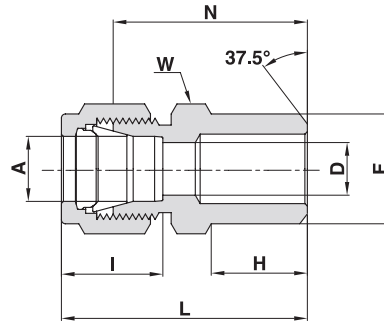

TUBE (INCH)

Ordering Information	A Tube O.D.		F Pipe Size		D		W Hex. Flat	N		H		L		I	
	inch	mm	inch	mm	inch	mm	inch	inch	mm	inch	mm	inch	mm	inch	mm
768LN _ 1/8 X 1/8	1/8	3.17	1/8	10.30	.09	2.28	7/16	.94	23.88	.38	9.65	1.20	30.48	.50	12.7
768LN _ 3/16 X 1/8	3/16	4.76	1/8	10.30	.12	3.04	7/16	.97	24.60	.38	9.65	1.23	31.25	.54	13.7
768LN _ 1/4 X 1/8	1/4	6.35	1/8	10.30	.19	4.82	1/2	1.00	25.40	.38	9.65	1.29	32.77	.60	15.2
768LN _ 1/4 X 1/4	1/4	6.35	1/4	13.70	.19	4.82	9/16	1.20	30.48	.56	14.22	1.49	37.85	.60	15.2
768LN _ 5/16 X 1/8	5/16	7.93	1/8	10.30	.20	5.08	9/16	1.05	26.67	.38	9.65	1.34	34.04	.64	16.2
768LN _ 5/16 X 1/4	5/16	7.93	1/4	13.70	.25	6.35	9/16	1.23	31.24	.56	14.22	1.52	38.61	.64	16.2
768LN _ 3/8 X 1/4	3/8	9.52	1/4	13.70	.28	7.11	5/8	1.28	32.51	.56	14.22	1.57	39.87	.66	16.8
768LN _ 3/8 X 3/8	3/8	9.52	3/8	17.10	.28	7.11	11/16	1.28	32.51	.56	14.22	1.57	39.87	.66	16.8
768LN _ 3/8 X 1/2	3/8	9.52	1/2	21.34	.28	7.11	7/8	1.53	38.86	.75	19.05	1.82	46.22	.66	16.8
768LN _ 3/8 X 3/4	3/8	9.52	3/4	26.67	.28	7.11	1 1/16	1.59	40.38	.75	19.05	1.88	47.75	.66	16.8
768LN _ 1/2 X 3/8	1/2	12.70	3/8	17.10	.41	10.41	13/16	1.31	33.27	.56	14.22	1.71	44.43	.90	22.9
768LN _ 1/2 X 1/2	1/2	12.70	1/2	21.34	.41	10.41	7/8	1.53	38.86	.75	19.05	1.93	49.00	.90	22.9
768LN _ 1/2 X 3/4	1/2	12.70	3/4	26.67	.41	10.41	1 1/16	1.59	40.40	.75	19.05	1.99	50.55	.90	22.9
768LN _ 1/2 X 1	1/2	12.70	1	33.40	.41	10.41	1 3/8	1.87	47.50	.94	23.87	2.27	57.65	.90	22.9
768LN _ 5/8 X 1/2	5/8	15.87	1/2	21.34	.50	12.70	15/16	1.53	38.86	.75	19.05	1.93	49.02	.96	24.4
768LN _ 3/4 X 1/2	3/4	19.05	1/2	21.34	.53	13.46	1 1/16	1.53	38.86	.75	19.05	1.93	49.00	.96	24.4
768LN _ 3/4 X 3/4	3/4	19.05	3/4	26.67	.62	15.74	1 1/16	1.59	40.40	.75	19.05	1.99	50.55	.96	24.4
768LN _ 1 X 1	1	25.40	1	33.40	.88	22.35	1 3/8	1.97	50.03	.94	23.87	2.45	62.23	1.23	31.2
768LN _ 1 1/4 X 1 1/4	*1 1/4	31.75	1 1/4	42.16	1.09	27.70	1 3/4	2.17	55.12	.94	23.88	3.04	77.22	1.62	41.2
768LN _ 1 1/2 X 1 1/2	*1 1/2	38.10	1 1/2	48.26	1.34	34.00	2 1/8	2.43	61.72	1.03	26.16	3.50	88.90	1.97	50.0
768LN _ 2 X 2	*2	50.80	2	60.33	1.81	45.97	2 3/4	3.00	76.20	1.06	26.92	4.47	113.34	2.66	67.6

Designation: Marking LN on Hex.

768 LW TUBE SOCKET WELD UNION

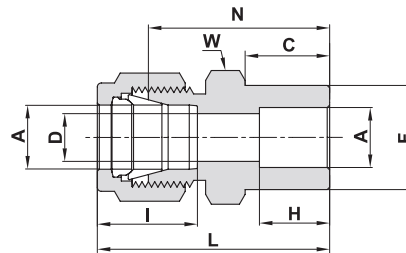

TUBE (INCH)

Ordering Information	A Tube O.D.		C		D		W Hex. Flat	F		H		I		L		N	
	inch	mm	inch	mm	inch	mm	inch	inch	mm	inch	mm	inch	mm	inch	mm	inch	mm
768LW _ 1/8 X 1/8	1/8	3.17	.34	8.64	.09	2.28	7/16	.31	7.87	.25	6.35	.50	12.70	1.14	28.96	.88	22.35
768LW _ 1/4 X 1/4	1/4	6.35	.41	10.41	.19	4.80	1/2	.44	11.18	.31	7.90	.60	15.20	1.32	33.53	1.03	26.16
768LW _ 3/8 X 3/8	3/8	9.52	.47	11.94	.28	7.10	5/8	.62	15.75	.38	9.65	.66	16.80	1.48	37.60	1.19	30.23
768LW _ 1/2 X 1/2	1/2	12.70	.47	11.94	.41	10.40	13/16	.75	19.05	.50	12.70	.90	22.90	1.62	41.15	1.22	31.00
768LW _ 3/4 X 3/4	3/4	19.05	.47	11.94	.62	15.80	1 1/16	1.05	26.67	.56	14.20	.96	24.40	1.71	43.43	1.31	33.28
768LW _ 1 X 1	1	25.40	.56	14.22	.88	22.35	1 3/8	1.36	34.54	.75	19.05	1.23	31.20	2.07	52.58	1.59	40.40

Designation: Marking LW on Hex.

"D" - Dimension is minimum opening. Dimensions are for reference only, and are subject to change without notice.