

Level sensor

Magnetostrictive, high-resolution measuring principle

Models FFG-P, FFG-T, FFG-TP, FLM-H

KSR data sheet FFG-P, FFG-T, FFG-TP, FLM-H



Applications

- High-accuracy level measurement for almost all liquid media
- Chemical, petrochemical, natural gas, offshore, shipbuilding, machine building, power generating equipment, power plants
- Process water and drinking water treatment, food industry, pharmaceutical industry

Special features

- Process- and system-specific solutions possible
- Operating limits:
 - Operating temperature: $T = -90 \dots +400 \text{ }^\circ\text{C}$
 - Operating pressure: $P = \text{Vacuum to } 100 \text{ bar}$
 - Limit density: $\rho \geq 400 \text{ kg/m}^3$
- Resolution $< 0.1 \text{ mm}$
- Wide variety of different electrical connections, process connections and materials
- Explosion-protected versions

Description

The model FFG-P, FFG-T, FFG-TP and FLM-H sensors are used for the high-accuracy, continuous level measurement of liquids and are based on determining the position of a magnetic float according to the magnetostrictive measuring principle.



Level sensor
Model FFG-T, flange connection

Model	Description
FFG-P	Standard version
FFG-T	High-temperature version
FFG-TP	Plastic version
FLM-H	Sterile version

Further special features

- Large scope of application due to the simple, proven functional principle
- Process connection, guide tube and float from stainless steel 1.4571, 1.4435, 1.4539 or plastic
- For harsh operating conditions, long service life
- Continuous measurement of levels, independent of physical and chemical changes of the media such as: Foaming, conductivity, dielectric constant, pressure, vacuum, temperature, vapours, condensation, bubble formation, boiling effects, density change
- Signal transmission over long distances
- Simple installation and commissioning, onetime calibration only, no recalibration necessary.
- Level displayed proportional to volume or height
- Parallel measurement of interface layer and overall level possible via HART® interface

Options

- Customised solutions
- Process connection, guide tube material and float from special steel, titanium, Hastelloy (others on request)
- In combination with limit switch, stepless setting of the limit values over the entire measuring range

Illustration of the principle

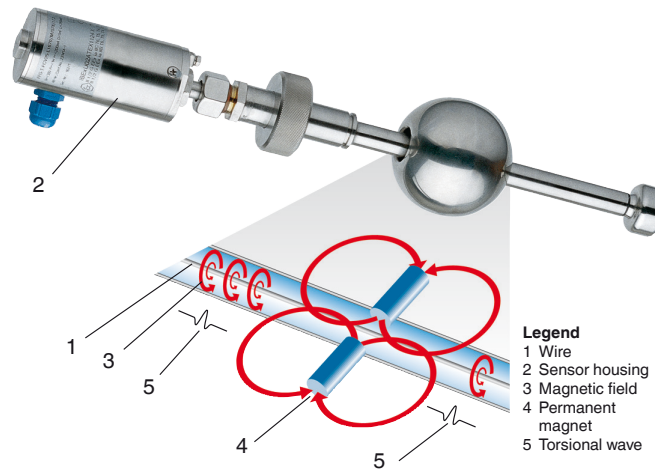

Design and operating principle

- The measuring process is triggered by a current impulse. This current produces a circular magnetic field (3) along a wire (1) made of magnetostrictive material fixed in the guide tube.
- At the point being measured (liquid level) there is a float with permanent magnets (4) acting as a position transducer.
- The interaction of both magnetic fields generates a mechanical torsion wave (5) in the wire.
- This is converted into an electrical signal at the end of the wire in the sensor housing (2) by a piezoceramic converter.
- The measured propagation delay enables the origination point, and thus the float position, to be determined with high accuracy.

Product overview

Sensor model	Description	Materials						Temperature range (process)
		Stainless steel 1.4571 (316Ti)	Stainless steel 1.4404 (316L)	Titanium 3.7035 (grade 2)	Stainless steel 1.4435 (316L)	PP	PVDF	
FFG-P	Magnetostrictive sensor, standard	x	x	x				-60 ... +185 °C
FFG-T	Magnetostrictive sensor, high temperature	x	x	x				-90 ... +400 °C
FFG-TP	Magnetostrictive sensor, plastic					x	x	-10 ... +100 °C
FLM-H	Magnetostrictive sensor, sterile version		x		x			-40 ... +400 °C

Sensor model	Approval (Option)			
	without	Ex i	Ex d	3A
FFG-P	x	x	x	
FFG-T	x	x		
FLM-H	x			x

Ex approvals

Explosion protection	Ignition protection type	Model	Zone	Approval number
ATEX	Ex i	FFG-T-Ex i	Zone 0	IBExU 02 ATEX 1124 X II 1/2G Ex ia IIC T3 ... T6
	Ex i	FFG-P.22H2...	Zone 0	ZELM 10 ATEX 0439 II 1/2G Ex ia IIC T3 ... T6
	Ex d	FFG-P.22H3...	Zone 1	ZELM 13 ATEX 0508 X II 1/2G Ex d IIB T3 to T6 Ga Gb

Type approval

Approval	Model	Approval number
EAC-Ex	FFG-	RU C-DE.GB08.B.00845
EAC	FFG-	TC N RU D-DE.AU14.B.21532
3A	FLM-H	3-A Sanitary Standards 74-06

Sensor, standard, model FFG-P

Process connection, guide tube and float from stainless steel 1.4571

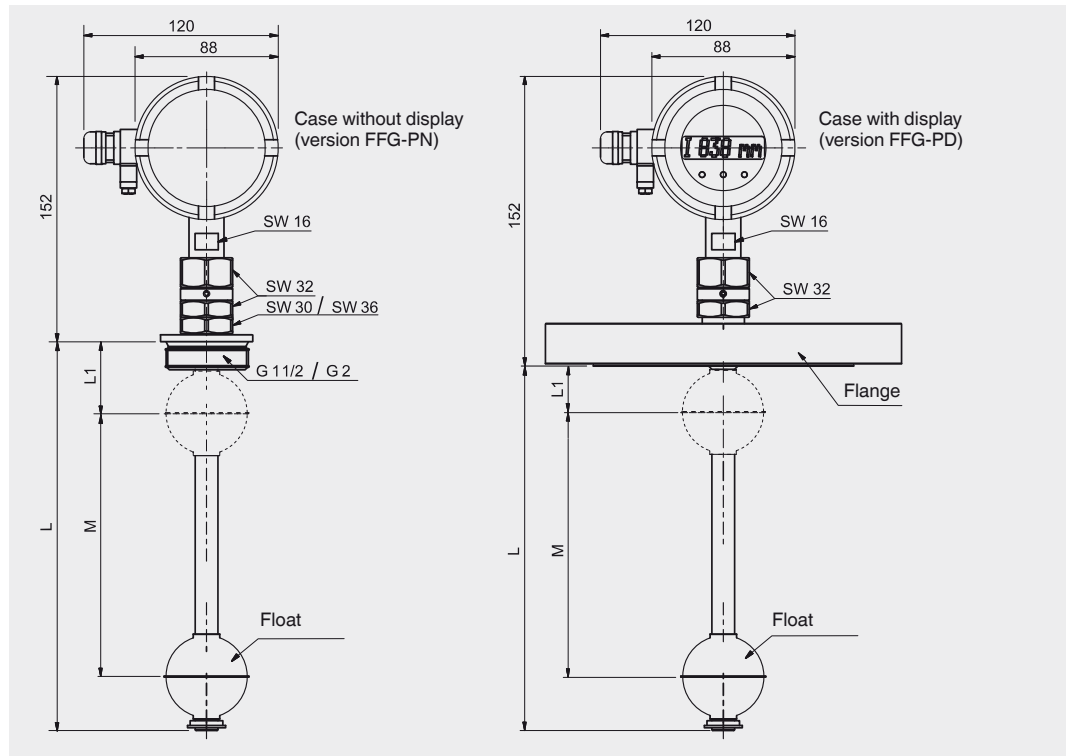

	Mounting thread	Flange
Electrical connection	Sensor housing, material stainless steel 1.4404 (316L) Version FFG-PN without display Version FFG-PD with window and display	
Display	LCD matrix (only version FFG-PD)	
Process connection	Mounting thread downwards G 1 1/2 or G 2	Mounting flange ■ DIN DN 50 ... DN 200, PN 6 ... PN 100 ■ ANSI 2" ... 8", class 150 ... 600
Guide tube diameter	14 mm 18 mm	14 mm 18 mm
Guide tube length L max.	3,000 mm 5,800 mm	3,000 mm 5,800 mm
Float	Material stainless steel 1.4571 (option: Titanium) Float diameter from 44 ... 120 mm Float selection depending on guide tube diameter and process conditions (see page 8) Attention: With Ex approval no floats from titanium may be used.	
Max. operating pressure	40 bar (100 bar with float from titanium), see table on page 8	
Temperature range Standard	Medium: -60 ... +185 °C Ambient temperature: - Standard, version without display -40 ... +85 °C - Standard, version with display -20 ... +70 °C - Version Ex i T3/T4/T5: -20 °C ... +70 °C, T6: -20 °C ... +60 °C - Version Ex d T3/T4/T5: -20 °C ... +70 °C, T6: -20 °C ... +60 °C	
Output signal	4 ... 20 mA, HART®	
Power supply	DC 15 ... 30 V	
Measuring accuracy	< ±0.5 mm	
Resolution	< 0.1 mm	
Load	max. 900 Ω at 30 V	
Mounting position	Vertical ±30°	
Ingress protection	IP 67 per EN 60529 / IEC 60529	

Sensor, high temperature, model FFG-T

Process connection, guide tube and float from stainless steel 1.4571

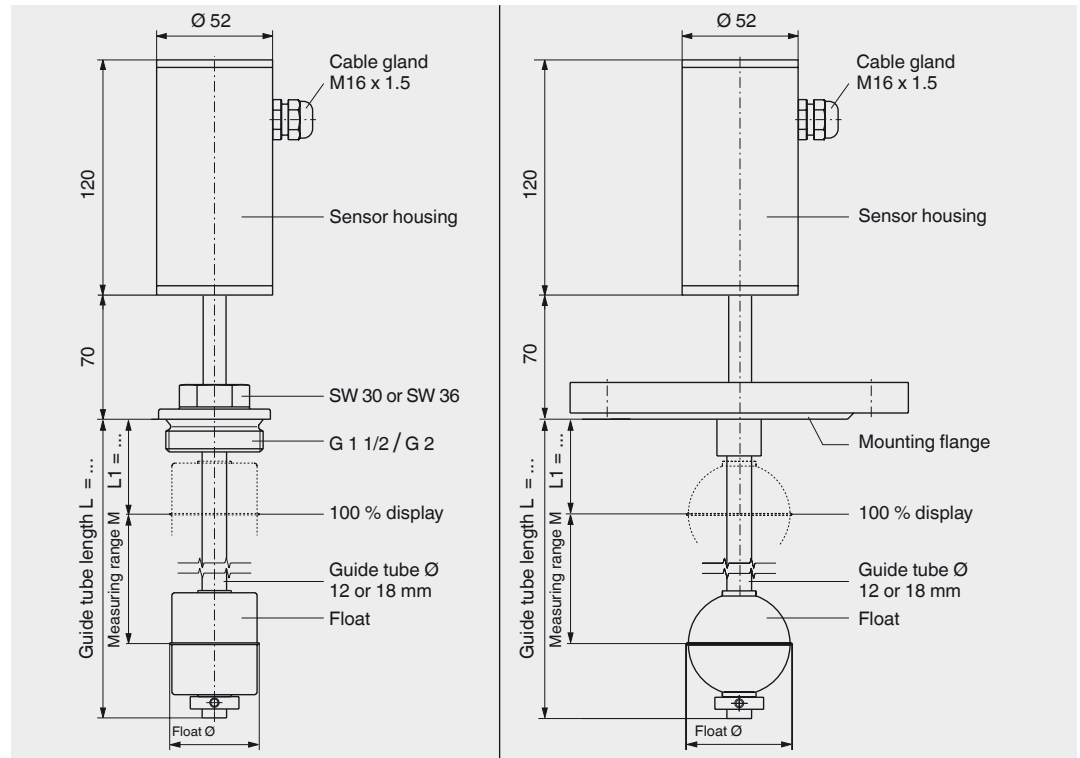

	Mounting thread		Flange	
Electrical connection	Sensor housing, material stainless steel 1.4301			
Process connection	Mounting thread downwards G 1 1/2 or G 2		Mounting flange ■ DIN DN 50 ... DN 200, PN 6 ... PN 100 ■ ANSI 2" ... 8", class 150 ... 600	
Guide tube diameter	12 mm	18 mm	12 mm	18 mm
Guide tube length L max.	3,000 mm	6,000 mm	3,000 mm	6,000 mm
Float	Material stainless steel 1.4571 (option: Titanium) Float diameter from 44 ... 120 mm Float selection depending on guide tube diameter and process conditions (see page 8)			
Max. operating pressure	40 bar (100 bar with float from titanium), see table on page 8			
Temperature range Standard	Medium: - Version FFG-TH: -45 ... +400 °C - Version FFG-TT: -90 ... +125 °C Ambient temperature: -40 ... +85 °C			
Output signal	4 ... 20 mA, HART®			
Power supply	DC 10 ... 30 V			
Measuring accuracy	< ±0.5 mm			
Resolution	< 0.1 mm			
Load	max. 900 Ω at 30 V			
Mounting position	Vertical ±30°			
Ingress protection	IP 68 per EN 60529 / IEC 60529			

Sensor, plastic, model FFG-TP

Process connection, guide tube and float from PVC, polypropylene or PVDF

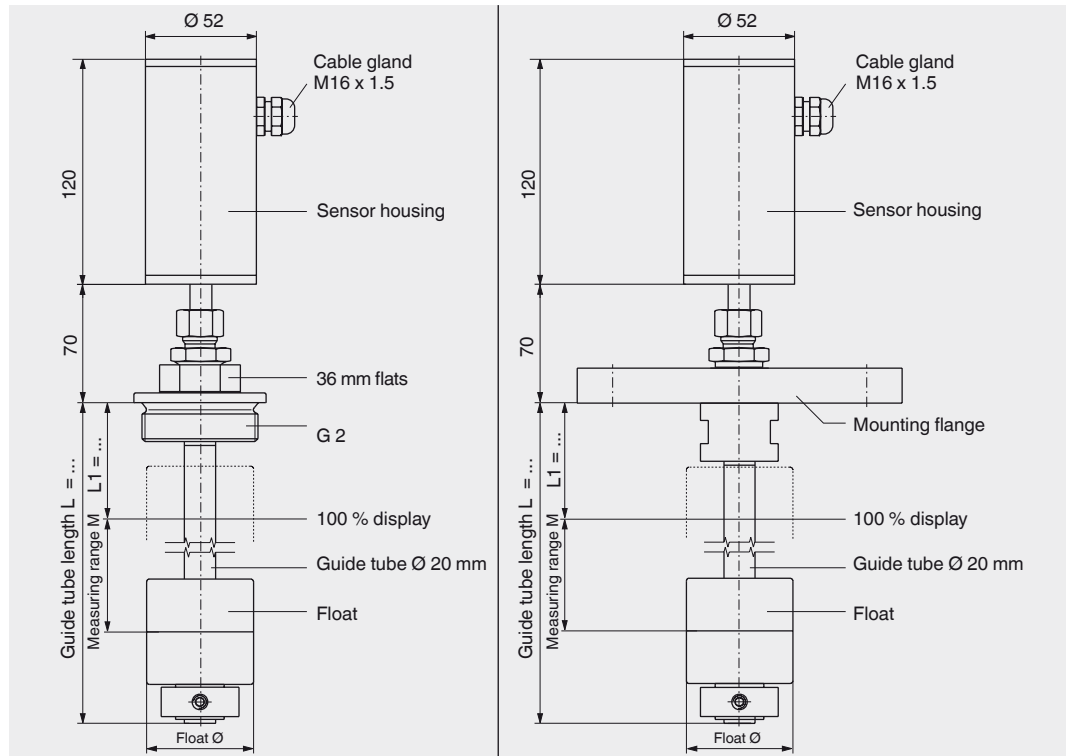

	Mounting thread	Flange
Electrical connection	Sensor housing, material stainless steel 1.4301	
Process connection	Mounting thread downwards G 1 1/2 or G 2	Mounting flange ■ DIN DN 50 ... DN 200, PN 6 ... PN 100 ■ ANSI 2" ... 8", class 150 ... 600
Guide tube diameter	16 or 20 mm	
Guide tube length L max.	5,000 mm	
Float	Material ■ Polypropylene ■ PVDF Float diameter of 55 or 80 mm Float selection depending on guide tube diameter and process conditions (see page 8)	
Max. operating pressure	3 bar	
Temperature range Standard	Medium: ■ Polypropylene -10 ... +80 °C ■ PVDF -10 ... +100 °C Ambient temperature: -40 ... +85 °C	
Output signal	4 ... 20 mA, HART®	
Power supply	DC 10 ... 30 V	
Measuring accuracy	< ±0.5 mm	
Resolution	< 0.1 mm	
Load	max. 900 Ω at 30 V	
Mounting position	Vertical ±30°	
Ingress protection	IP 68 per EN 60529 / IEC 60529	

Sensor, sterile version, model FLM-H

Process connection, guide tube and float from stainless steel 1.4435 (316L) or 1.4404 (316L), surface ground and polished
 $R_a < 0.8 \mu\text{m}$ or $R_a < 0.4 \mu\text{m}$, alternatively electropolished

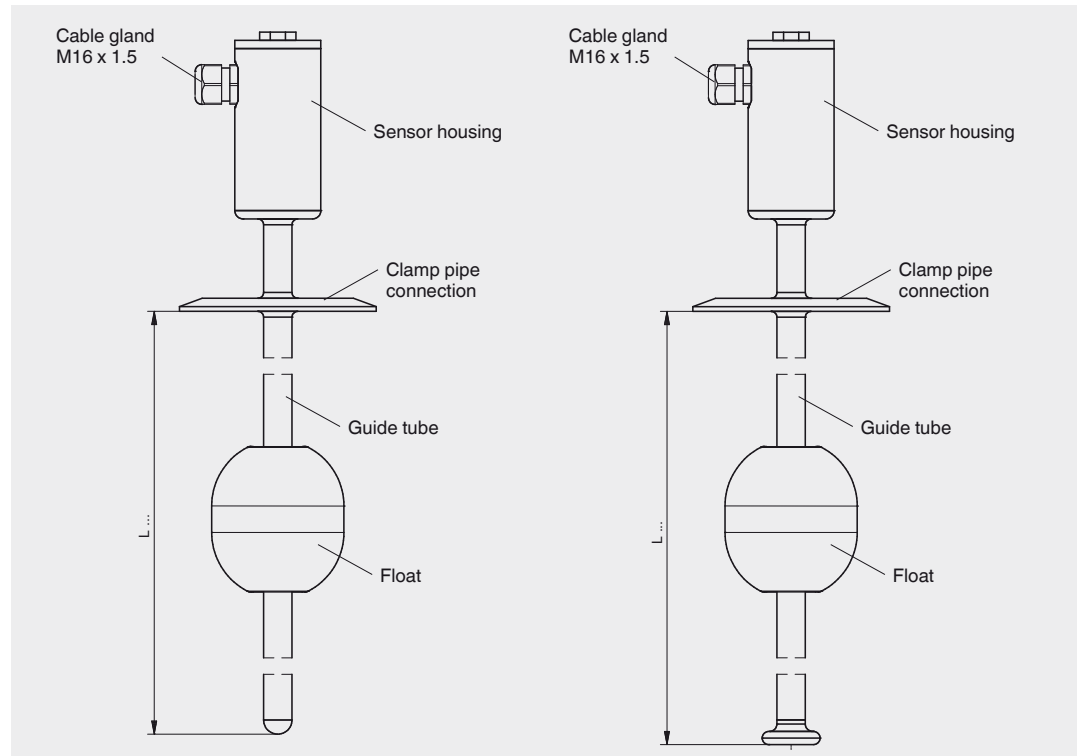

	Version without floor fixture	Version with separate floor fixture
Electrical connection	Sensor housing, material stainless steel 1.4305	
Process connection	Clamp ISO 2852 Clamp DIN 32767 Aseptic thread DIN 11864-1 Aseptic collar connecting sleeve DIN 11864-1 Aseptic flange DIN 11864-2 Aseptic clamp DIN 11864-3 VARIVENT® BioConnect®	
Guide tube diameter	17.2 mm	
Guide tube length L max.	6,000 mm	
Float	Material stainless steel 1.4435 (316L) or 1.4539 (316L) Float diameter of 80 mm Float selection depending on guide tube diameter and process conditions (see page 8)	
Max. operating pressure	10 bar	
Temperature range Standard	Medium: - Standard, version FLM-H: -40 ... +250 °C - High temperature, version FLM-HT: -40 ...+400 °C Ambient temperature: -40 ... +85 °C	
Output signal	4 ... 20 mA, HART®	
Power supply	DC 10 ... 30 V	
Measuring accuracy	< ±0.5 mm	
Resolution	< 0.1 mm	
Load	max. 900 Ω at 30 V	
Mounting position	Vertical ±30°	
Ingress protection	IP 68 per EN 60529 / IEC 60529	

Spherical floats (K)

Cylindrical floats (Z)

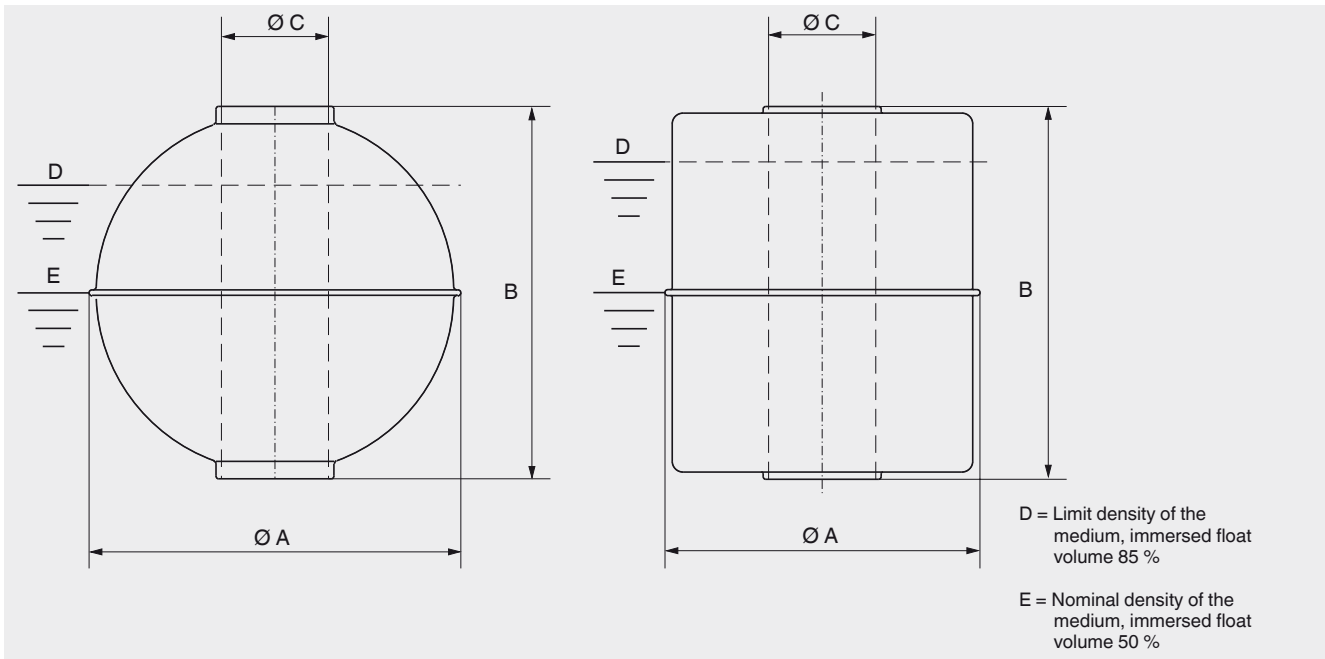

Material	Version	Suits guide tube Ø mm	Form	Ø A mm	B mm	Ø C mm	Max. Operating pressure bar	Max. Operating temperature °C	Limit density 85 % kg/m ³	Nominal density 50 % kg/m ³
Stainless steel 1.4571 (316Ti)	V44A	14	Z	44	52	15	16	200	818	1.390
	V52A	14	K	52	52	15	40	200	769	1.307
	V62A	14	K	62	61	15	32	200	597	1.015
	V83A	14	K	83	81	15	25	200	408	693
	V80A	18	K	80	76	23	25	200	679	1.155
	V98A	18	K	98	96	23	25	200	597	1.016
	V105A	18	K	105	103	23	25	200	533	907
	V120A	18	K	120	117	23	25	200	389	661
	V120/38A	18	K	120	116	38	25	200	537	914
	Titan 3.7035 (Grade 2)	T44A	14	Z	44	52	15	16	200	720
T52A		14	K	52	52	15	25	250	707	1.201
T52/1A		14	K	52	52	15	110	250	1040	1.770
T62A		14	K	62	62	15	25	250	505	859
T83A		14	K	83	81	15	25	250	278	473
T80A		18	K	80	76	23	25	250	665	1.130
T98A		18	K	98	96	23	25	250	595	841
T105A		18	K	105	103	23	25	250	369	627
PVC	P55A	16	Z	55	54	22	3	60	798	1.357
	P80A	20	Z	80	79	25	3	60	537	974
Polypropylen	PP55A	16	Z	55	54	22	3	80	582	989
	PP80A	20	Z	80	79	25	3	80	431	723
PVDF	PF55A	16	Z	55	69	22	3	100	821	1.396
	PF80A	20	Z	80	79	25	3	100	681	1.157
Sterile version										
Stainless steel 1.4435 (316L)	V80/88/R4/3A/35	17.2	K	80	88	23	16	150	790	1.350
Stainless steel 1.4539 (316L)	V80/R4/3A/39	17.2	K	80	76	23	16	150	621	1.056

Note: The optimum float will be selected after a feasibility test carried out by KSR.

Ordering information

Model / Version / Electrical connection / Process connection / Guide tube diameter / Guide tube length (insertion length) L / 100 % mark L1 / Measuring range M (span 0 % - 100 %) / Process specifications (operating temperature and pressure, limit density) / Options

© 2014 KSR KUEBLER Niveau-Messtechnik AG, all rights reserved.
The specifications given in this document represent the state of engineering at the time of publishing.
We reserve the right to make modifications to the specifications and materials.



KSR KUEBLER Niveau-Messtechnik AG
Heinrich-Kuebler-Platz 1
69439 Zwingenberg/Germany
Tel. +49 6263 87-0
Fax +49 6263 8799
info@ksr-kuebler.com
www.ksr-kuebler.de